

DIMET

CATHODIC PROTECTION

DIMET

The **DIMET** brand has been established in the Cathodic Protection Field since 1970 and is renowned worldwide. The **DIMET** experience has given us unsurpassed knowledge in the design, manufacture, installation, commissioning and maintenance of the full range of sacrificial anodes, impressed current cathodic protection systems and other corrosion prevention methods.

DIMET brand cathodic protection and corrosion prevention products and services are provided by **SBN Industries Sdn Bhd** in Malaysia together with an extensive group of affiliates in the other parts of the world.

Our consultant-cum-design team of engineers are available to provide advice on all aspects of corrosion prevention, especially cathodic protection.

QUALITY ASSURANCE AND CONTROL

DIMET anodes are cast in modern foundry, using only the highest purity material. In process, spectrographic anode analysis is performed in a well equipped computerised laboratory to ensure consistent compliance with quality standards.

Similar high quality standards can be expected from all products and services provided under the **DIMET** brand.

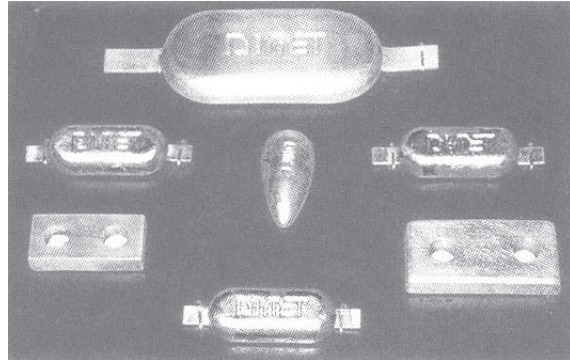

Anodes



SBN's DIMET Cathodic Protection Division has the most qualified and experienced group of Corrosion Engineers in South East Asia. Services available from this Division on a consulting or lump sum basis include:-

FIELD SURVEYS

- Soil and water resistivity, PH, Redox potential and pipe to soil potential surveys/measurements
- Offshore platform potential surveys
- Pearson (pipe location) survey, coating inspection
- Corrosion investigations including stray current analysis
- Interference study and mitigation

DESIGN

- Conceptual or detailed design of Cathodic Protection Systems including material lists, installation drawings and instructions

SUPERVISION

- Field supervision of Cathodic Protection installation by experienced Corrosion Engineers and Technicians

COMMISSIONING

- Complete commissioning of Cathodic Protection Systems including full report, maintenance instructions and training of site personnel

MAINTENANCE

- Periodic surveys of existing Cathodic Protection Systems to ensure optimum performance



SBN and its overseas affiliates manufacture and supply all **DIMET** Cathodic Protection materials and instruments. These include:-

GALVANIC ANODES

- DIMETAL aluminium anodes and **DIMET** zinc anodes including:
 - Offshore structural anodes (for platforms, jetties, wharves, etc)
 - Offshore submarine pipeline bracelet anodes
 - Onshore prepackaged anodes
 - Marine anodes (for hull, tank, etc)
 - Pressure vessel anodes
- DIMET magnesium anodes for underground structures

IMPRESSED CURRENT ANODES

- Silicon/Chromium/Iron anodes
- Platinised Titanium/Niobium, MMO anodes
- Lead/Silver/Antimony anodes
- Graphite anodes

TRANSFORMER RECTIFIERS

- Custom built cathodic protection transformer rectifiers

INSTRUMENT

- Copper sulphate, silver chloride, zinc reference electrodes, etc.
Distributor for M.C. Miller's instruments and accessories

INSULATING EQUIPMENT

- Distributor for "PSI" flange insulating kits and casing insulators

OTHERS

- "Pile-Gard" in-situ splash zone wrapping system capable of achieving 20 years performance
- FRP jacket splash zone wrapping system
- "Dimet 410T" solventless 100% epoxy for underwater repair
- "Dimet 103" anti-fouling system up to 3 years protection against anti-fouling capable to be applied underwater
- Cathodic Protection test points, resistance bond boxes, special cathodic protection electrical cable

CORROSION

Corrosion results from an electrochemical reaction. It requires an anode, a cathode, a common electrolyte, and an electrical connection between the two zones. The corrosion process results in the flow of a small electric current from the anode to the cathode through the electrolyte. The magnitude of the current, which is due to a number of factors, is directly proportional to the metal lost due to corrosion. One ampere flowing for one year would result in the loss of 9 kgs of steel from a corroding surface.

For many years cathodic protection has found a general acceptance amongst engineers and structure owners as being a truly effective method of preventing corrosion under the ground or under the sea. It is now common to find cathodic protection being used on marine structures and on buried pipelines.

The concept of cathodic protection is straight forward. Corrosion occurs as the result of electrochemical reactions between zones of differing potential on a metal surface. Oxidation (corrosion) occurs at the anodic zone and reduction (no corrosion) occurs on the cathodic zone. Cathodic Protection is achieved when an entire metal surface is converted to a cathodic zone.

The corrosion reactions at each surface may be described as:

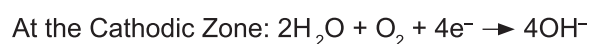
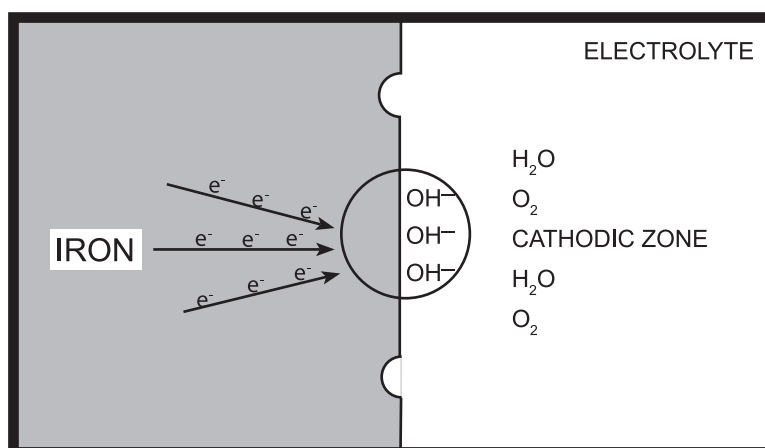
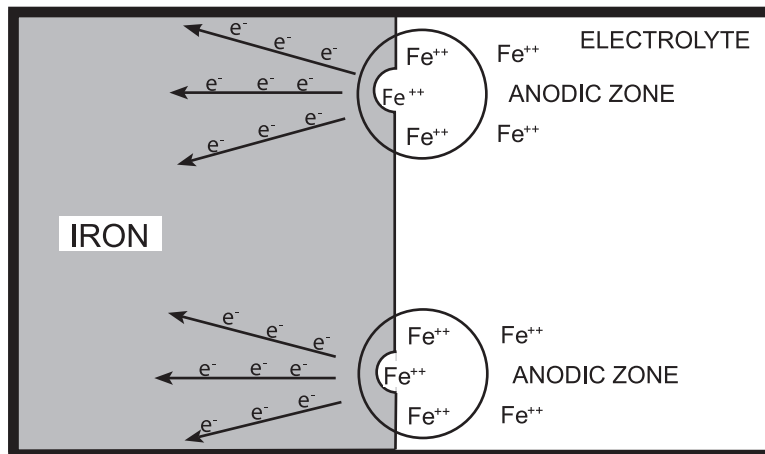

SACRIFICIAL ANODES

Sacrificial Anodes are most commonly used to protect metallic structures in electrolytes because of their simplicity of installation and maintenance free operation. Of the alloys available for sacrificial anodes, alloys of aluminium have proven to be the most economical in seawater or very low resistivity muds.

Knowing the total submerged and buried steel areas, the water resistivity and the required system life, a Corrosion Engineer can determine precisely what energy will be required to protect a structure and can design a galvanic system to suit the environment requirements.

Freely corroding mild steel in seawater has a resultant potential between anode and cathode of approximately -0.50 to -0.60 volts compared to a silver/silver chloride reference electrode. When cathodic protection is applied, it will be noted that the surface potential of steel will change to more negative than -0.80 volts when measured relative to a silver/silver chloride reference cell. Thus by using this simple practical measurement, it is possible to determine whether corrosion has been completely eliminated or not.

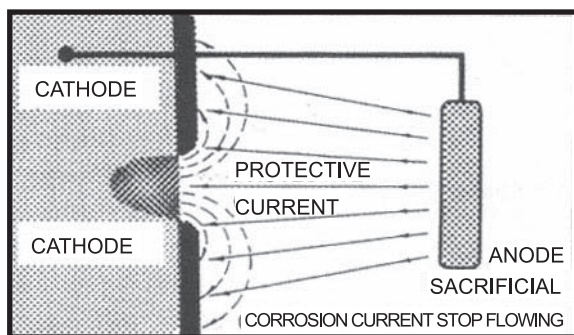

Flow of corrosion current suppressed by protective current discharged from sacrificial anodes

IMPRESSED CURRENT SYSTEMS

Impressed Current Systems provide the same electric current as galvanic anodes by the discharge of D.C. current from a relatively inert anode energised from an external D.C. power source such as a transformer rectifier or thermo electric generator. Impressed current system anodes include materials such as silicon iron, platinized precious metals, lead alloys and graphite.

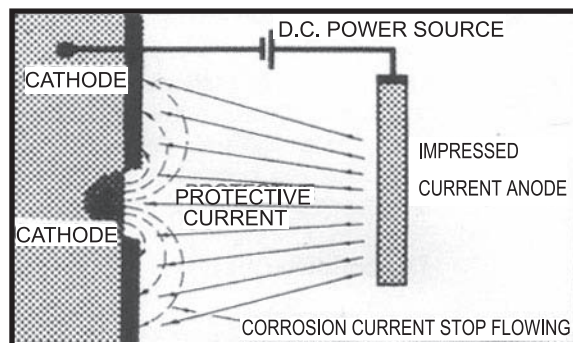

Flow of corrosion current suppressed by protective current discharged from impressed current system

Effective cathodic protection guarantees corrosion free existence. Providing the structure is maintained at a potential of -0.8 volts (or more negative) no loss of metal will occur at all during the life of the structure. As cathodic protection can be renewed or added during the life of the structure, the maintenance of the desired potential is readily achievable. The efficacy of the system can be monitored by a simple electrical measurement.

Cathodic Protection, apart from overcoming the more 'normal' causes of corrosion, may be used to counter accelerated corrosion resulting from contact between different metals, from impingement by high velocity water, from the effects of sulphate reducing bacteria and from the effects of stray D.C. currents.

OFFSHORE STRUCTURES

The submerged and buried steel work of the jacket of an offshore platform is usually left uncoated, and cathodic protection is solely applied to protect these areas. Sacrificial anodes for platforms are generally cast with tubular steel cores which are welded to the jacket bracing members. The current discharged from the anodes will protect the entire steel structure including the buried pipe piles and well castings.

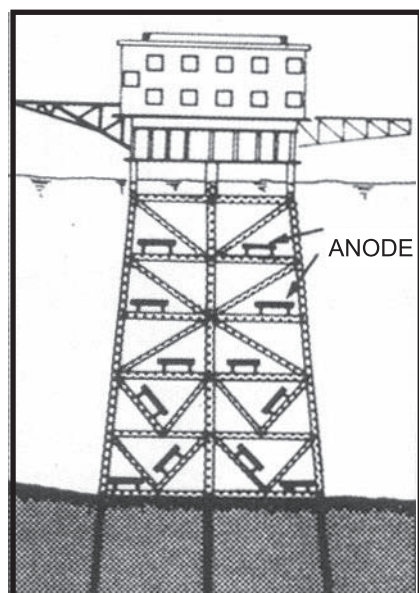

Offshore jacket installed with sacrificial anode system to protect the submerged and buried steel surface

Impressed Current System may also be employed to protect a fixed offshore structure. In designing a system of this type, particular care must be taken with anode placement to ensure that the spread of protection is uniform and the anodes and their connection cables and hardware are not subject to damage during normal platform operation.

In the case where continuous monitoring of the platform potential is required, permanent potential monitoring equipment including the monitoring anodes, and monitoring instruments can be installed on the platform. However, very often, in shallow and mild environments, periodical surveys by using portable survey instrument will provide a sufficiently detailed and accurate potential profile of the structure.

The columns or legs of jack up drilling rigs are generally coated with high performance protective coatings whereas the spud cans or mat are often left uncoated.

When designing a cathodic protection system for a jack-up rig, the constraints by the rig operations must be taken into consideration. This would require the positioning of the anodes on the legs or spud can so as not to disrupt the jacking operations or transit of the rig.

If an impressed current system is chosen to protect the submerged external steel surfaces, then a retrievable anode system will be found to be appropriate. The anodes may be recovered while the rig is in transit.

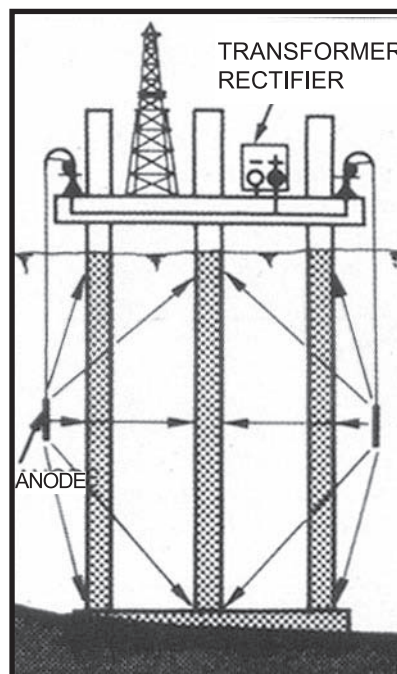

Jack up rig installed with impressed current system to protect the submerged steel surface

For the protection of a semi-submersible rig, anodes installed on the columns and hull or pontoon would be flush mounted to minimise resistance during transit.

Internal areas of the spud can or mat are invariably fitted with sacrificial anodes. The type and quantity of anodes are designed to ensure every compartment and corners of the tank internals are receiving full protection until the end of the anode design life.

DIMET

JETTIES AND WHARVES

CATHODIC PROTECTION APPLICATIONS

Submerged fixed structural steel in a marine environment is one of the most critical areas for cathodic protection. Steel piling of these structures is often coated to some 3 to 5 metres below low water and is left bare below the depth. Designers of these structures rely predominantly on cathodic protection to protect submerged and buried steel surfaces.

The effective use of cathodic protection has been recognised by a number of institutions who previously did not install cathodic protection on their structures. Visual surveys generally indicate a smooth unaffected areas of steel. However, they do not reveal that the metal can be corroding uniformly over the entire structure. Wall thickness measurements with modern ultrasonic equipment can be used to determine that the steel thickness has been reduced by a significant percentage of the total thickness.

Galvanic anode systems or impressed current systems may be used for protection of wharves or jetties steel piles. The choice of system type is governed by the availability and cost of electricity, the proximity of skilled personnel for maintenance and other considerations such as the possibility of physical damage or theft. In the case of land backed sheet piled wharves, the landward face of the steel piles can be most economically protected by an impressed current system. For dolphins which are remote from the wharves and where power is not available, sacrificial anodes are generally installed.

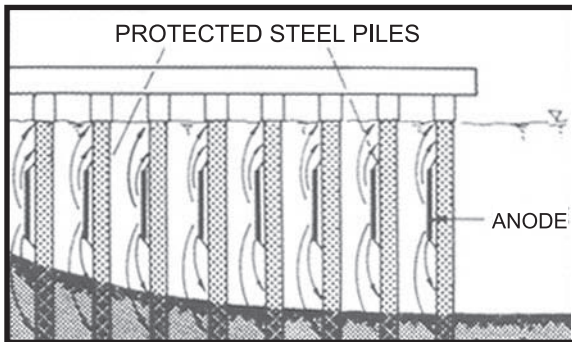

Jetty steel piles protected by sacrificial anodes

With sacrificial anode systems, a large number of anodes are distributed throughout the piles and because of the even distribution of anodes, the level of protection is usually very uniform. Protection from impressed current systems may be less uniform due to fewer anodes emitting larger currents but correct design can ensure full protection in all areas without excessive energy wastage in areas close to anodes.

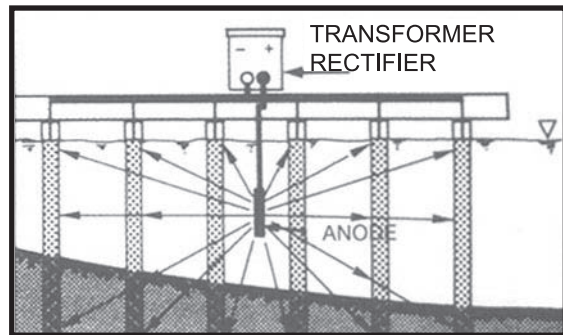

Jetty steel piles protected by an impressed current system

On jetties or wharves that have reinforced concrete decking as distinct from a steel superstructure, electrical interconnection of the piles is necessary for the operation of the system. Professional advice from a Corrosion Engineer should be sought in designing a pile bonding system.

Each structure has its own peculiarities. The Corrosion Engineer will look at the structure as a whole and design a system which will protect not just the structure but all submerged or buried steel work associated with it.

Structure location, water temperature, water depth, depth to toes of pile and pile sizes must be considered in designing a cathodic protection system for these structures.

ONSHORE PIPELINES

It is common practice to use cathodic protection in conjunction with pipe coatings to prevent corrosion on the external surfaces of buried pipelines.

On critical pipelines such as those operating at very high pressure and/or operations failure of which will result in catastrophes or very expensive shut downs, a Corrosion Engineer is normally employed to conduct a corrosion survey along the pipe route and to prepare an accurate design and specification.

The engineer may choose to use sacrificial anodes or an impressed current system or a combination of both to protect the pipeline. As a general rule if local electricity supply is available then an impressed current system may be energised by a transformer rectifier. In remote areas, in-line generators, solar cells or thermoelectric generators may be required. Sacrificial magnesium alloy anodes may also be installed under certain circumstances.

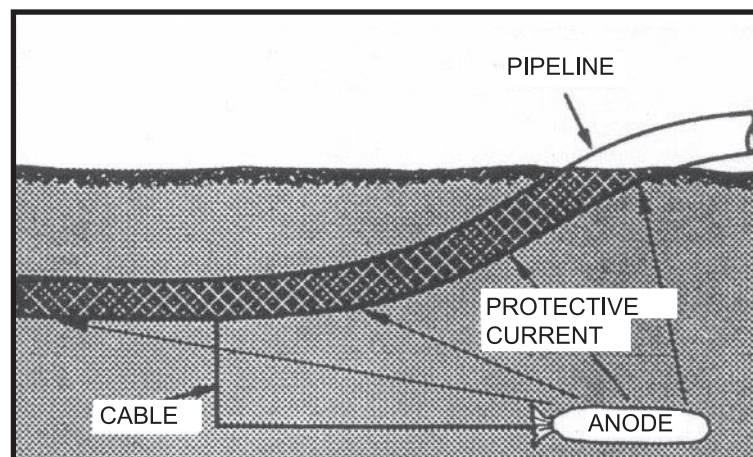

External surface of the onshore buried pipeline protected by sacrificial anode against corrosion

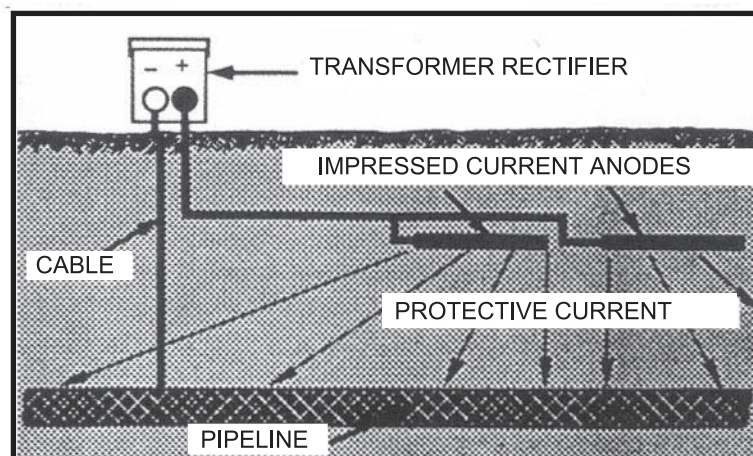

External surface of the onshore buried pipeline protected by an impressed current system

Cathodic Protection may be used alone to protect a buried structure but it is common practice to incorporate a coating on economical grounds. This same comment applies to buried tanks and to a lesser extent the protection of the external surface of tank bottoms in a tank farm.

The internal surfaces of pipelines conveying an electrolyte may also be cathodically protected, although it is not quite as straight forward as the protection of exterior surfaces. As a general rule, the larger the pipe diameter the easier it is to apply cathodic protection.

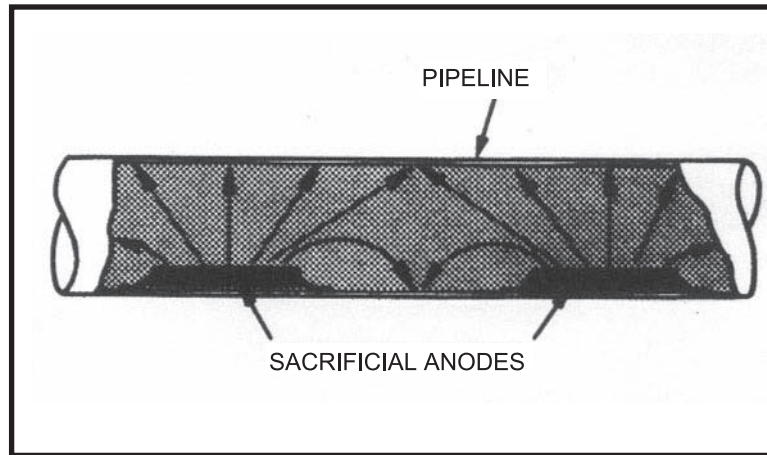

Pipeline internal protected against corrosion by sacrificial anodes

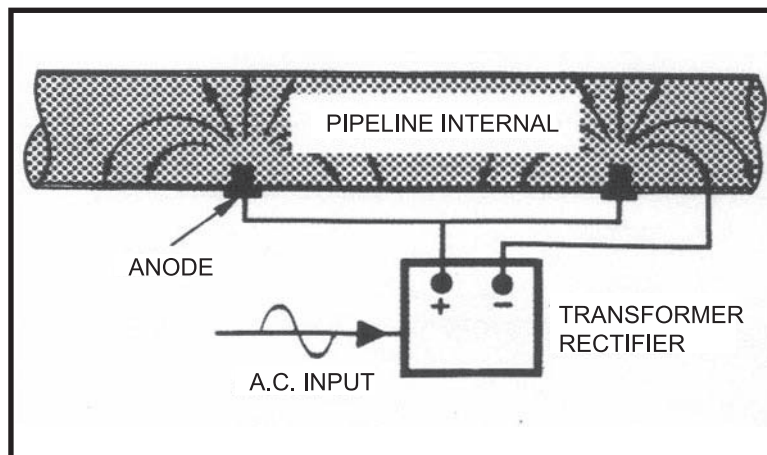

Pipeline internal protected against corrosion by an impressed current system

SUBMARINE PIPELINES

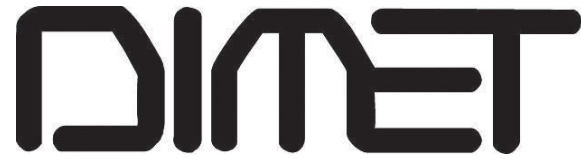

CATHODIC PROTECTION APPLICATIONS

SUBMARINE PIPELINES

Subsea pipelines carrying gas, oil or other fluid are usually coated with corrosion resistant coating and may be concrete weight coated. These pipelines are usually protected by either aluminium or zinc anodes in bracelet form installed at regular intervals.

To ensure smooth operation in laying of the pipelines, the cylindrical bracelet anodes are sized to be flushed with the pipeline concrete weight coating. For non-concrete weight coated pipelines, the anodes are designed tapered to avoid blockage.

Depending on the operating temperature of the pipeline and the environmental conditions, the engineer will choose to use zinc or aluminium bracelet anodes. Following data would be required for the design of pipeline bracelet anodes:-

- Pipeline outside diameter
- Pipe wall thickness
- Corrosion coating thickness
- Concrete weight coating thickness
- Length of the pipeline
- Design life of the pipeline
- Operating temperature of the pipeline

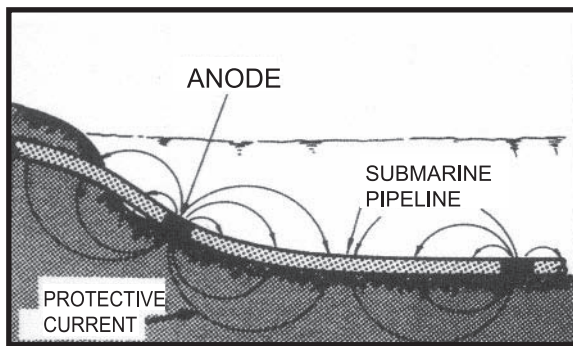

Submarine pipeline protected against corrosion by sacrificial bracelet anodes

In some cases, the pipelines may be protected by an Impressed Current System. The system can be operated either independently or tied with other structure such as platform or wharf impressed current system. In either of these cases, the choice of the anode type would be determined by the environmental conditions, maintenance and installation constraints.

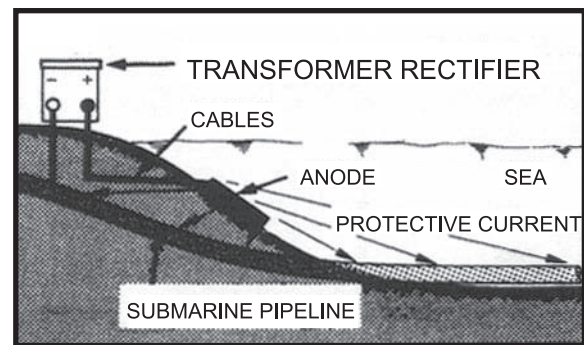

Corrosion protection of submarine pipeline by impressed current system

To avoid the drainage of cathodic protection current to other foreign metallic structures, the pipelines are electrically isolated at ends by insulating flanges. This is particularly important where submarine pipelines are protected by galvanic anodes to prevent accelerated consumption of the anodes.

Since the mid 1950's cathodic protection has been used to prevent corrosion on heat exchangers, industrial plant and water cooling equipment. The present equipment is manufactured to a high degree of sophistication which includes automatic control, data gathering and processing systems.

As with all cathodic protection systems either sacrificial anodes or impressed current systems may be used successfully on these equipment. There are two important factors which will influence the choice of the system: the metal from which the equipment is fabricated and the velocity and temperature of the water flowing over or through the equipment.

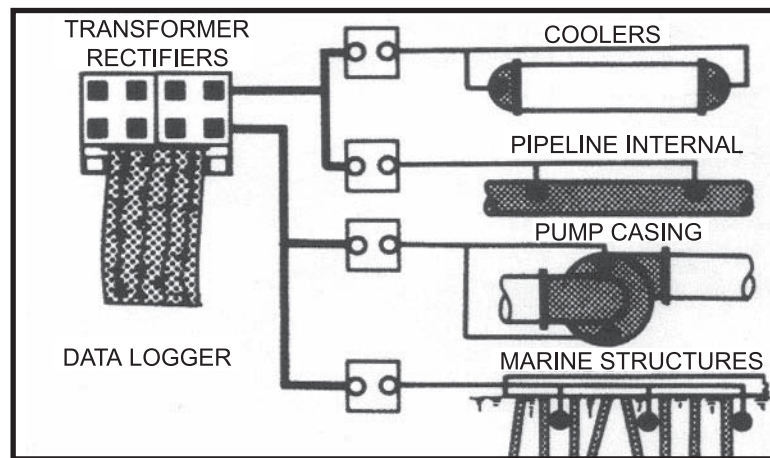

In addition to the general information listed above the designer of an industrial cathodic protection system should know:-

- Water temperature and composition variations
- Water velocity
- Materials used in the equipment construction
- Equipment operating cycles
- The need to incorporate monitoring of the cathodic protection system in the overall data retrieval system

The design of industrial and power station cathodic protection systems requires a high degree of skill and expertise. Tri-Star engineers are fortunate in having this experience available to them.

GENERAL

Effective cathodic protection of ship hulls and similar marine structures in seawater against corrosion has been widely demonstrated for many years using either zinc or aluminium alloy sacrificial anodes. Magnesium alloy is applicable in fresh water conditions and other specialised purposes such as the electrolytic descaling of cargo tanks using high purity magnesium ribbon.

SHIP HULLS

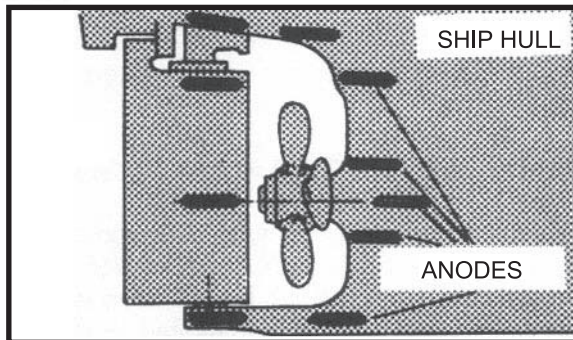

Cathodic Protection is normally applied to the whole underwater hull which includes the typically cavitation – corrosion prone areas around the stern and in particular inside kort nozzles and bow thrusters where extremely high water velocities are experienced. Anodes are also fitted in recesses such as seawater inlet boxes where shielding from exterior hull protection may occur.

The design period of protection usually coincides with the duration between dockings and the system generally requires no maintenance or attention during this period provided the original design is correct.

In short, an accurate design requires correct information and data to be furnished to the Corrosion Engineer:-

- Vessel's principal dimensions
- Duration required for protection
- Choice of anode alloy preferred
- Define hull coating applied
- Specify anode attachment method preferred
- Define water environment where vessel operates if other than normal seawater
- Any special features of the vessel must be highlighted for inclusion into the basic design e.g. kort nozzles, bow thrusters, etc.

Impressed Current Systems using flush mounted anodes are often used on very large vessel such as VLCC's or ULCC's where the quantity of sacrificial anodes to be installed would be prohibitive. The output of these systems can be automatically controlled to cater for damage or deterioration of the hull coating system or variation in speed or water environment.

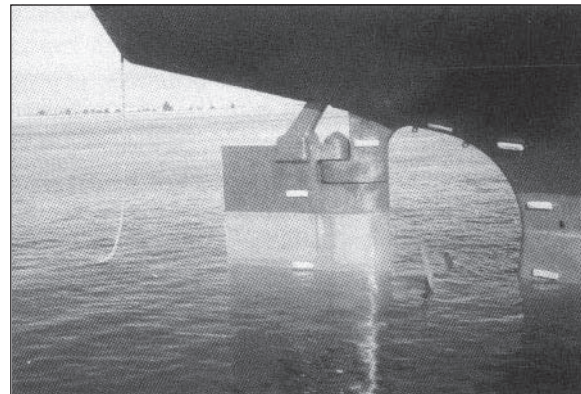

SEAWATER/PETROLEUM CARGO BALLAST TANKS

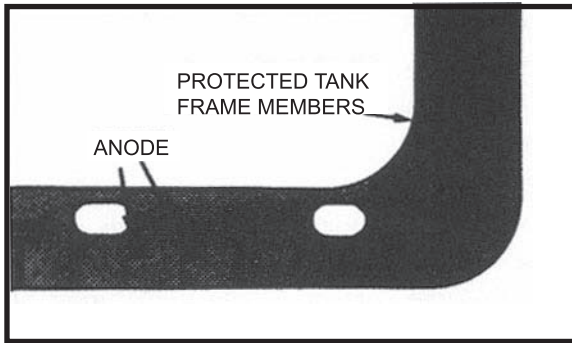

An approved system of corrosion control can be in the form of coatings, anodes or a combination of both coatings and anodes. Where sacrificial anodes are employed, the anode material is either zinc or aluminium alloy. Magnesium anodes are not permitted in oil cargo tanks or tanks adjacent to them owing to the possibility of a flint action spark caused by metal parts falling on the fitted anodes or vice versa.

Under the Classification Society Rules, aluminium anodes are only permitted in petroleum cargo tanks in locations where the potential energy does not exceed 28 kgm with the anode height measured from the tank bottom to the centre of the anode. Where aluminium anodes are mounted on horizontal surfaces such as bulkhead girders and stringers, the height of the anode is measured from these surfaces. There is no restriction on the use and positioning of zinc anodes in petroleum cargo tanks.

The following input information should be furnished to the Corrosion Engineer to ensure a precise and adequate design of the cathodic protection system:-

- Tank dimensions, preferably with drawings showing tanks internal layout
- Specify whether tanks used solely for seawater or seawater/cargo ballast
- Duration required for protection, usually 4 years
- Choice of anode alloy preferred
- Define ballast condition or frequency
- Define internal tank coating system, if any
- Specify anode attachment method either direct weld on, clamp on or bolt on

PETROLEUM TANKER 'LAY UP' SYSTEM

Portable sacrificial anode systems are commonly employed to provide cathodic protection to the underwater hull areas and ballast tanks when a vessel is 'laid up' for a period of time. Protection is by means of long slender anodes of either zinc or aluminium alloy suspended from the ship/tank side by cables. The system is designed more or less in line with the standard design for ship hulls and ballast tanks with some exceptions made to the design criteria used and suitable modifications for suspension of anodes.

The above review on the application of cathodic protection to ships and related structures is aimed to give a wider appreciation of the subject and remove some of the misconceptions with respect to this means of preventing corrosion.

Corrosion is inevitable but its prevention, employing sound engineering principles, can result in significant savings in the operations of any fixed or floating marine equipment.

ALUMINIUM

The DIMET Aluminium Alloy Anodes are cast from the highest purity aluminium ingot to conform to the following material composition:-

Requirement For Chemical Composition Limits

Element	Chemical Composition (%)	
	DIMETAL IIIA	DIMETAL IIIB
Zinc	3.0 – 5.0	3.0 - 5.0
Indium	0.01 – 0.02	0.01 - 0.02
Titanium	0.02 - 0.05	-
Silicon	0.15 max.	0.18 max.
Iron	0.12 max.	0.10 max.
Copper	0.006 max.	0.006 max.
Other Impurities	0.02 each max.	0.02 each max.
Aluminium	Remainder	Remainder
Anode Potential (vs Ag/AgCl Ref. cell)		
Open Circuit	-1.10 volts ± 30 mV	-1.10 volts ± 30 mV
Closed Circuit	-1.07 volts ± 30 mV	-1.07 volts ± 30 mV
Electrochemical capacity in seawater		
@ Ambient Temp.	2500 – 2730 Amp.hr/kg	2450 – 2730 Amp.hr/kg
Consumption rate in seawater		
@ Ambient Temp.	3.21 – 3.50 kg/Amp.Yr	3.21 – 3.57 kg/Amp.Yr
Efficiency	85% to 92%	85% to 92%



DIMET ZINC ALLOY

E N G I N E E R I N G

I N F O R M A T I O N

ZINC

The **DIMET** zinc alloy anodes are cast to internationally recognised U.S. Military Specification MIL-18001-H using only special high grade zinc ingot of minimum purity 99.995% with small additions of special alloy elements.

Requirement For Chemical Composition Limits

<u>Element</u>	<u>Chemical Composition (%)</u>
Lead	0.006 max.
Iron	0.005 max.
Cadmium	0.025 – 0.15
Copper	0.005 max.
Aluminium	0.10 – 0.50
Silicon	0.125 max.
Zinc	Remainder
Open circuit potential (vs Ag/AgCl ref. cell)	-1.05 volt
Electrochemical capacity in seawater @ Ambient temperature	780 Amp.hr/kg
Consumption rate in seawater @ Ambient temperature	11.25 kg/Amp.Yr

DIMET zinc anodes have stable electrochemical properties and are used in seawater or in water resistivity up to 1000 ohm-cm. They should not be used where environmental temperature may exceed 50°C.

MAGNESIUM

DIMET magnesium anodes are cast to the following material composition:-

Requirement For Chemical Composition Limits

<u>Element</u>	<u>Chemical Composition (%)</u>	
	MAGNESIUM STANDARD	MAGNESIUM HIGH POTENTIAL
Aluminium	5.3 – 6.7	0.01 max.
Zinc	2.5 – 3.5	-
Manganese	0.15 – 0.70	0.50 - 1.3
Copper	0.05 max.	0.05 max.
Silicon	0.30 max.	0.02 max.
Iron	0.03 max.	0.03 max.
Nickel	0.003 max.	0.001 max.
Others (each)	0.30 max.	0.05 max.
Others (total)	-	0.30 max.
Magnesium	Remainder	Remainder
Open circuit potential (vs Cu/CuSo ₄ ref. cell)	-1.55 volt	-1.75 volt
Electrochemical capacity in seawater @ Ambient temperature	1105 Amp.hr/kg	1100 Amp.hr/kg
Consumption rate in seawater @ Ambient temperature	7.9 kg/Amp.Yr	8.0 kg/Amp.Yr

DIMET magnesium anodes are the best all round choice for underground application. The alloy is economical and is suitable for low to moderate resistivity soils.

DIMET

FORMULAE

ANODE TO FIELD RESISTANCE

For slender anode:

$$R = \frac{\rho}{2\pi L} \left(\ln \frac{4L}{r} - 1 \right)$$

where L is the anode length (cm)
r is the anode radius (cm)
ρ is the resistivity (ohm.cm)

For plate anode:

$$R = \frac{\rho}{a + b}$$

where a is the anode length (cm)
b is the anode width (cm)

For bracelet anode:

$$R = \frac{0.315 \rho}{\sqrt{A}}$$

where A is the exposed surfaces (cm²)

ANODE WEIGHT CALCULATION

$$W = \frac{T \times 8760 \times A \times I}{1000 \times C \times U}$$

where W = Total alloy weight required (kg)
T = Life time (year)
A = Surface area (m²)
I = Current density (mA/m²)
C = Current capacity of the alloy (Amp.hr/kg)
U = Utilisation factor (e.g. 0.9 for slender anode, 0.8 for bracelet anode)

DIMET

GENERAL DATA

GALVANIC SERIES

METAL

Magnesium	-1.5 to -1.7
Zinc	-1.05
Aluminium or Zinc anode	-1.00 to -1.1
Commercial pure aluminium	-0.65 to -0.8
Clean mild steel in seawater/soil	-0.5 to -0.7
Rusted mild steel in seawater/soil	-0.3 to -0.5
Mild steel in concrete	-0.2 to -0.3
Brass, bronze	-0.2 to -0.3
Copper	-0.2

OPEN CIRCUIT POTENTIAL VS AG/AGCL REF. ELECTRODE (VOLTS)

-1.5 to -1.7
-1.05
-1.00 to -1.1
-0.65 to -0.8
-0.5 to -0.7
-0.3 to -0.5
-0.2 to -0.3
-0.2 to -0.3
-0.2

CORROSIVENESS OF SOIL

Soil resistivity less than 1,000 ohm.cm	Severely corrosive
1,000 to 5,000 ohm.cm	Corrosive
5,000 to 10,000 ohm.cm	Moderately corrosive
More than 10,000 ohm.cm	Less corrosive with increase in resistivity

TYPICAL DESIGN CURRENT DENSITY

South East Asia	55 – 65
Persian Gulf	55 – 90
North Sea	85 – 220
Gulf Of Mexico	55 – 65
US West Coast	75 – 110

DIMET ALUMINIUM PLATFORM ANODES

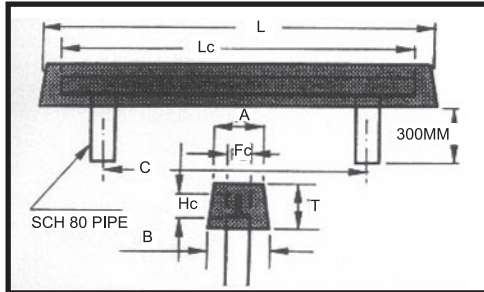
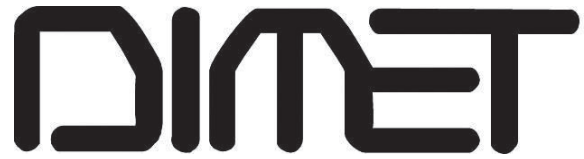

ANODE TYPE	ALLOY WT (KG)	GROSS WT (KG)	L (mm)	A (mm)	B (mm)	T (mm)	C (mm)	SCH 80 PIPE DIA. (ins)	LxHxFcxThk (mm)
A1200SOPT	120	133	2000	148	173	141	1600	2	1800x50x50x6
A1470SOPT-1	147	160	2120	148	176	160	1600	2	1800x50x50x6
A1470SOPT-2	147	162	2440	148	173	141	2073	2	2200x50x50x6
A2000SOPT	200	215	2440	148	181	186	1850	2	2200x50x50x6
A2600SOPT	260	294	2440	198	229	187	1850	3	2200x80x80x9
A3300SOPT	330	368	2440	252	290	188	1850	4	2200x80x80x9
A3500SOPT	350	388	2440	252	293	198	1850	4	2200x80x80x9

CORE: STAND-OFF PIPE WELDED TO TEE BAR.

NOTE: NON-STANDARD ANODES OF OTHER WEIGHTS/DIMENSIONS OR SPECIAL CORES ARE ALSO AVAILABLE ON REQUEST

ANODE TYPE	ALLOY WT (KG)	GROSS WT (KG)	L (mm)	A (mm)	B (mm)	T (mm)	C (mm)	SCH 80 PIPE DIA. (ins)	Lc (mm)
A1200SOSP	10	138	2000	148	175	152	1600	2	1800
A1470SOSP-1	147	165	2120	148	178	171	1600	2	1800
A1470SOSP-2	147	168	2440	148	175	153	2073	2	2200
A2000SOSP	200	221	2440	198	223	155	1850	2	2200
A2600SOSP	260	304	2440	198	232	209	1850	3	2200
A3300SOSP	330	394	2440	252	296	216	1800	4	2200
A3500SOSP	350	414	2440	252	299	226	1850	4	2200

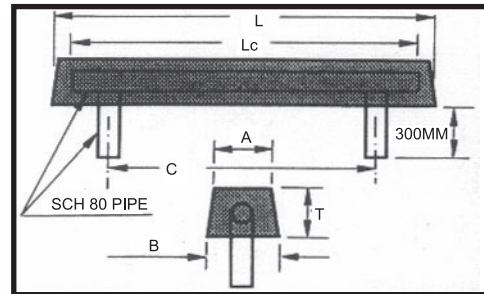

CORE: STAND-OFF STRAIGHT PIPE

NOTE: NON-STANDARD ANODES OF OTHER WEIGHTS/DIMENSIONS OR SPECIAL CORES ARE ALSO AVAILABLE ON REQUEST

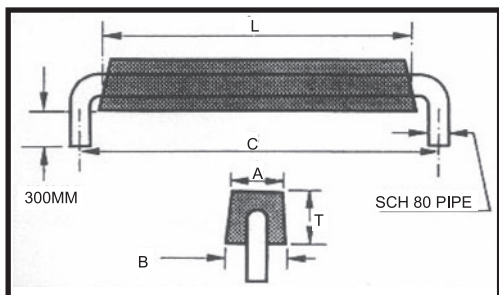

ANODE TYPE	ALLOY WT (KG)	GROSS WT (KG)	L (mm)	A (mm)	B (mm)	T (mm)	C (mm)	SCH 80 PIPE DIA. (ins)
A1200SOBP	120	141	2000	148	175	153	2200	2
A1470SOBP	147	172	2440	148	176	154	2840	2
A2000SOBP	200	225	2440	198	224	156	2840	2
A2600SOBP	260	311	2440	198	232	211	2840	3
A3300SOBP	330	407	2440	252	297	217	3040	4
A3500SOBP	350	427	2440	252	299	227	3040	4
A6190SOBP	619	707	2440	300	362	326	3040	4

CORE: STAND-OFF BENT PIPE

NOTE: NON-STANDARD ANODES OF OTHER WEIGHTS/DIMENSIONS OR SPECIAL CORES ARE ALSO AVAILABLE ON REQUEST

STRUCTURAL ANODES

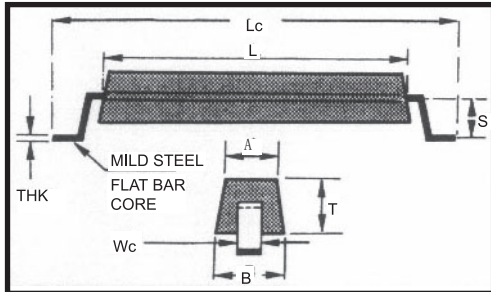

ANODE TYPE	ALLOY WT (KG)	GROSS WT (KG)	L (mm)	A (mm)	B (mm)	T (mm)	S (mm)	LcxWcxThk (mm)
A345DCFB	34.5	40	1250	89	115	103	135	1600x50x9
A400DCFB	40	46	1500	89	115	102	135	2000x50x9
A600DCFB	60	66	1500	126	145	112	135	2000x50x9
A635DCFB	63.5	68	1020	148	174	144	135	1400x50x9
A800DCFB	80	87	1500	126	151	146	135	2000x50x9
A1100DCFB	110	117	1500	148	178	167	155	2000x50x9
A1400DCFB	140	154	1500	198	225	165	155	2000x75x12
A1600DCFB	160	181	2440	148	176	154	155	3000x75x12
A2000DCFB	200	221	2440	148	182	187	155	3000x75x12

CORE: STAND-OFF FLAT BAR

NOTE: NON-STANDARD ANODES OF OTHER WEIGHTS/DIMENSIONS OR SPECIAL CORES ARE ALSO AVAILABLE ON REQUEST

ANODE TYPE	ALLOY WT (KG)	GROSS WT (KG)	L (mm)	A (mm)	B (mm)	T (mm)	S (mm)	LcxCORE DIA. (mm)
A400SR/DCR	40	45	1500	89	114	101	135	2000x20
A600SR/DCR	60	65	1500	126	145	112	135	2000x20
A800SR/DCR	80	85	1500	126	151	146	135	2000x20
A1100SR/DCR	110	118	1500	148	178	167	155	2000x25
A1400SR/DCR	140	148	1500	198	225	165	155	2000x25
A1600SR/DCR	160	172	2440	148	175	151	155	3000x25
A2000SR/DCR	200	212	2440	148	181	185	155	3000x25

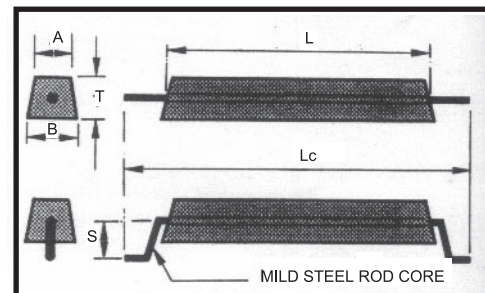

CORE: STRAIGHT ROD OR DOUBLE CRANKED ROD.

NOTES:

1. WHEN ORDERING, PLEASE SPECIFY SR OR DCR TYPE
2. NON STANDARD ANODES OF OTHER WEIGHTS/DIMENSIONS OR SPECIAL CORES ARE ALSO AVAILABLE ON REQUEST.

CYLINDRICAL BRACELET ANODES

DIMET

TYPE	O.D. (ins)	I.D. (ins)	THICKNESS T (ins)	LENGTH L (ins)	GAP G (ins)	NETT WT. (lbs)	CORE WT. (lbs)	GROSS WT. (lbs)
ABC 4-25/1	6.81	4.81	1	17.2	1.5	25	4	29
ABC 6-42/1	9	7	1	20	1.5	42	5	47
ABC 8-50/1	11	9	1	19	2	50	6	56
ABC 10-56/1	12	10	1	19	2	56	6	62
ABC 10-153/2	14.62	10.62	2	22.1	2	153	11	164
ABC 12-74/1	15.25	13.25	1	19.4	2	74	13	87
ABC 12-180/1.8	20.85	17.25	1.8	18.2	1.5	180	13	193
ABC 14-158/2	19.81	15.81	2	15.7	2	158	12	170
ABC 16-216/2	24.5	20.5	2	16.5	1.5	216	15	231
*ABC 18-197/2	22.5	18.5	2	17	2	197	14	211
ABC 24-238/4	32.25	24.25	4	7.5	3	238	24	262
*ABC 24-312/1.5	27.5	24.5	1.5	27.9	2	312	28	340
*ABC 30-375/1.5	33.5	30.5	1.5	27	2	375	33	408
ABC 30-388/2	34	30	2	20.7	2	388	23	411
ABC 36-418/4	44.25	36.25	4	9	3	418	34	452

* Anode with notch

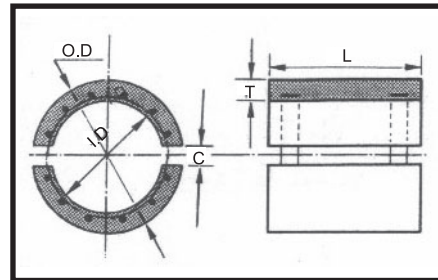

TYPE	O.D. (ins)	I.D. (ins)	THICKNESS T (ins)	LENGTH L (ins)	GAP G (ins)	NETT WT. (lbs)	CORE WT. (lbs)	GROSS WT. (lbs)
ZBC 4-65/1	6.81	4.81	1	17.2	1.5	65	4	69
ZBC 6-110/1	9	7	1	20	1.5	110	4	114
ZBC 8-88/1.5	12	9	1.5	8.1	2	88	3	91
ZBC 10-144/1	12	10	1	19	2	144	6	150
ZBC 10-395/2	14.62	10.62	2	22.1	2	395	11	406
ZBC 12-191/1	15.25	13.25	1	19.4	2	191	14	205
ZBC 12-467/1.8	20.85	17.25	1.8	18.2	1.5	467	13	480
ZBC 14-409/2	19.81	15.81	2	15.7	2	409	12	421
ZBC 16-191/1	18.56	16.56	1	15.8	1.5	191	24	215
ZBC 16-415/3	22	16	3	10	2	415	15	430
ZBC 18-370/1.25	20.81	18.31	1.25	22.6	3.5	370	27	397
*ZBC 18-511/2	22.5	18.5	2	17	2	511	13	524
ZBC 20-483/2	24.5	20.5	2	14.5	2	483	15	498
*ZBC 24-616/4	32.25	24.25	4	7.5	3	616	24	640
ZBC 30-1005/2	34	30	2	20.7	2	1005	23	1028
ZBC 36-1080/4	44.25	36.25	4	9	3	1080	35	1115

* Anode with notch

NOTE: NON-STANDARD ANODES OF OTHER WEIGHTS/DIMENSIONS OR SPECIAL CORES ARE ALSO AVAILABLE ON REQUEST

PIPELINE ANODES

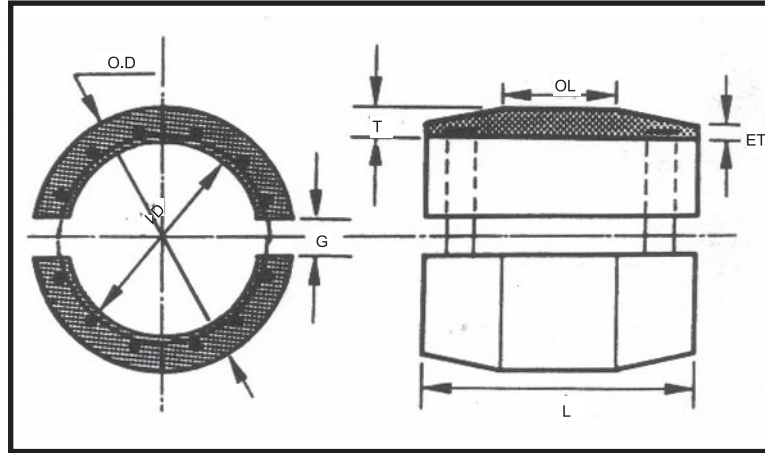

NOTE: NON-STANDARD ANODES OF OTHER WEIGHTS/DIMENSIONS OR SPECIAL CORES ARE ALSO AVAILABLE ON REQUEST

TYPE	O.D. (ins)	I.D. (ins)	THICKNESS T (ins)	TAPERED END THICKNESS, ET (ins)	LENGTH L (ins)	OUTER LENGTH, OL (ins)	GAP G (ins)	NETT WT. (lbs)	CORE WT. (lbs)	GROSS WT. (lbs)
ZBT 6-65/1	9.00	7.00	1.0	0.3	15.5	7.50	2.00	65	4	69
ZBT 6-113/1.25	9.00	6.50	1.25	0.2	21.5	13.50	2.00	113	5	118
ZBT 6-129/1.25	9.00	6.50	1.25	0.3	23.5	15.50	2.00	129	5	134
ZBT 6-144/1.5	9.25	6.25	1.5	0.3	21.6	15.00	2.00	144	4	148
ZBT 8-111/1.25	11.25	8.75	1.25	0.3	16.3	9.00	2.00	111	9	120
ZBT 10-127/1.5	14.00	11.00	1.5	0.03	12.8	6.125	1.50	127	6	133
ZBT 10-140/1.5	14.375	11.375	1.5	0.3	13.0	6.00	1.50	140	7	147
ZBT 10-141/1.5	14.25	11.25	1.5	0.03	13.0	8.00	2.00	141	6	147
ZBT 10-144/2	14.625	10.625	2.0	0.2	11.5	3.875	2.00	144	3	147
ZBT 10-199/1.5	13.75	10.75	1.5	1.1	16.5	11.50	2.00	199	11	210
ZBT 10-249/1.5	14.00	11.00	1.5	0.2	22.0	14.75	2.00	249	8	257
* ZBT 10-308/1.25	13.50	11.00	1.25	1.4	28.2	26.062	2.00	308	12	320
ZBT 12-171/1.25	15.313	12.813	1.25	0.3	16.9	9.50	2.00	171	13	184
* ZBT 12-428/1.5	15.75	12.75	1.5	1.3	29.0	21.00	2.00	428	13	441
ZBT 16-214/1.25	18.625	16.125	1.25	0.3	16.8	9.375	2.00	214	12	226

* Anode with notch

TYPE	O.D. (ins)	I.D. (ins)	THICKNESS T (ins)	TAPERED END THICKNESS, ET (ins)	LENGTH L (ins)	OUTER LENGTH, OL (ins)	GAP G (ins)	NETT WT. (lbs)	CORE WT. (lbs)	GROSS WT. (lbs)
ABT 6-25/1	9.00	7.00	1.0	0.3	15.5	7.5	2	25	4	29
ABT 6-44/1.25	9.00	6.50	1.25	0.2	21.5	13.5	2	44	5	49
ABT 6-50/1.25	9.00	6.50	1.25	0.3	23.5	15.5	2	50	5	55
ABT 6-56/1.5	9.25	6.25	1.5	0.3	21.6	15.0	2	56	4	60
ABT 8-43/1.25	11.25	8.75	1.25	0.3	16.2	9.0	2	43	9	52
ABT 10-50/1.5	14.00	11.00	1.5	0.03	12.7	6.1	1.5	50	6	56
ABT 10-54/1.5	14.25	11.25	1.5	0.03	13.0	8.0	2	54	6.5	60.5
ABT 10-55/1.5	14.375	11.375	1.5	0.3	13.0	6.0	1.5	55	7	62
ABT 10-56/2	14.625	10.625	2.0	0.2	11.5	3.9	2	56	3	59
ABT 10-77/1.5	13.75	10.75	1.5	1.1	16.5	11.5	2	77	11	88
ABT 10-96/1.5	14.00	11.00	1.5	0.2	22.0	14.7	2	96	8	104
*ABT 10-120/1.25	13.50	11.00	1.25	1.4	28.7	26.6	2	120	12	132
ABT 12-66/1.25	15.313	12.813	1.25	0.3	16.9	9.5	2	66	13	79
*ABT 12-165/1.5	15.75	12.75	1.5	1.3	29.0	21.0	2	165	13	178
ABT 16-83/1.25	18.625	16.125	1.25	0.3	16.7	9.4	2	83	12	95

* Anode with notch

DIMET ALUMINIUM HULL ANODES



BOLT ON TYPE

ANODE TYPE	GROSS WT (Kg)	L (mm)	W (mm)	T (mm)	Lc (mm)
A5B	0.7	200	100	20	110
A14B	1.8	305	76	36	205
A16B	1.8	200	100	30	110
A25B	2.7	300	150	25	160
A35B	3.7	300	150	30	160
A40B	4.2	300	150	40	160
A44B	5.0	456	102	53	230
A50B	5.2	300	150	50	160
A60B	6.2	300	200	40	160
A80B	8.2	300	200	50	160

NOTE: NON-STANDARD ANODES OF OTHER WEIGHTS/ DIMENSIONS OR SPECIAL CORES ARE ALSO AVAILABLE ON REQUEST

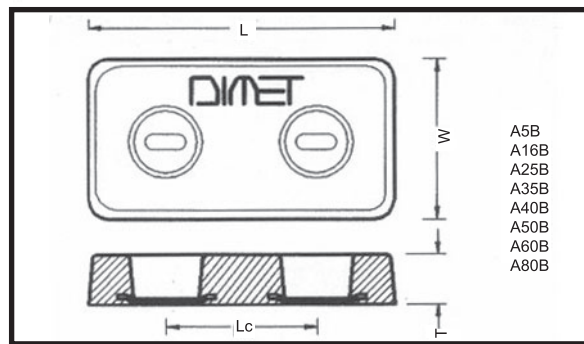
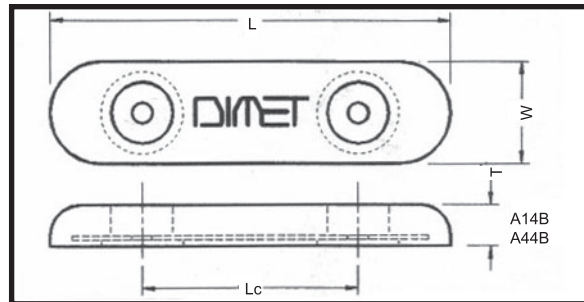

WELD ON TYPE

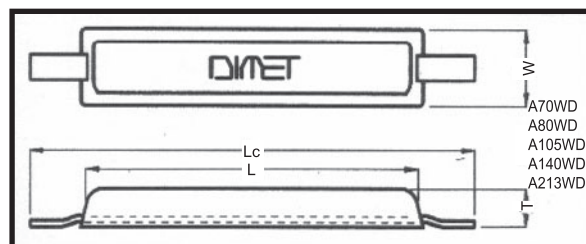
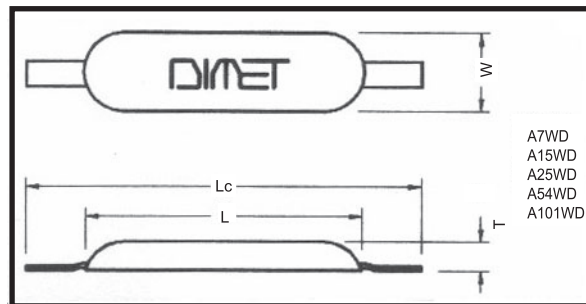
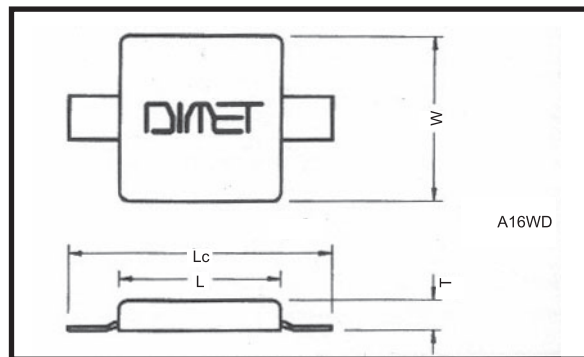
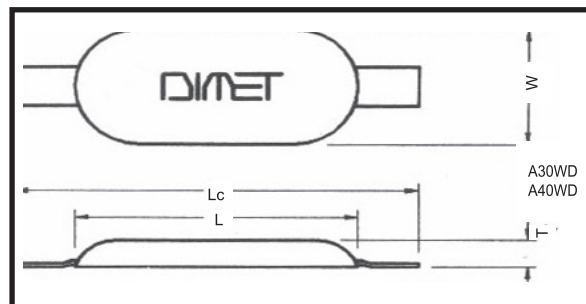

ANODE TYPE	GROSS WT (Kg)	L (mm)	W (mm)	T (mm)	Lc (mm)
A7WD	0.9	170	75	25	230
A15WD	2.1	305	75	38	425
A16WD	1.9	150	150	25	230
A25WD	3.2	305	90	45	455
A30WD	4	316	130	36	455
A40WD	5	305	152	38	455
A54WD	6.5	456	102	53	626
A70WD	8.5	585	134	37	750
A80WD	9.5	585	134	40	750
A105WD	13	585	142	53	750
A140WD	16.5	585	149	67	750
A213WD	25	900	140	67	1200

NOTE: NON-STANDARD ANODES OF OTHER WEIGHTS/ DIMENSIONS OR SPECIAL CORES ARE ALSO AVAILABLE ON REQUEST

DIMET

ZINC HULL ANODES

BOLT ON TYPE

ANODE TYPE	GROSS WT (Kg)	L (mm)	W (mm)	T (mm)	Lc (mm)
Z11B	1.3	150	75	25	75
Z22B	2.4	200	100	20	110
Z31B	3.3	200	100	30	110
Z36B	4.0	305	76	36	205
Z39B	4.1	200	100	40	110
Z69B	7.1	300	150	25	160
Z79B	8.1	300	150	30	160
Z100B	10.2	300	150	40	160
Z114B	12.0	456	102	53	230
Z134B	13.6	300	150	50	160
Z158B	16.0	300	200	40	160
Z200B	20.2	300	200	50	160

NOTE: NON-STANDARD ANODES OF OTHER WEIGHTS/ DIMENSIONS OR SPECIAL CORES ARE ALSO AVAILABLE ON REQUEST

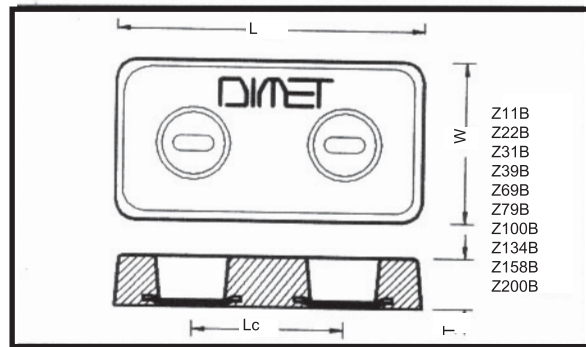
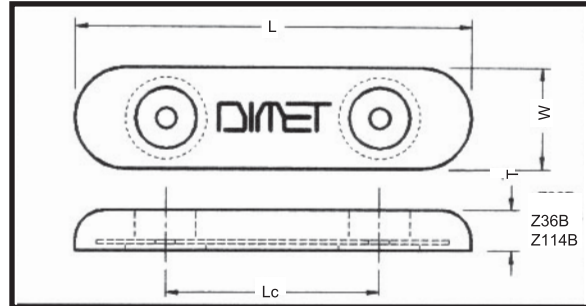

WELD ON TYPE

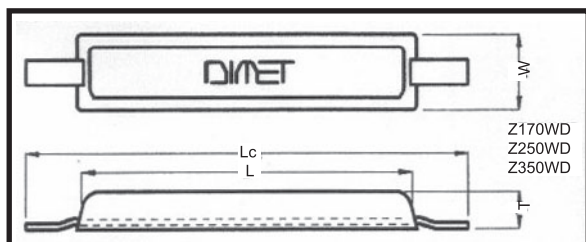
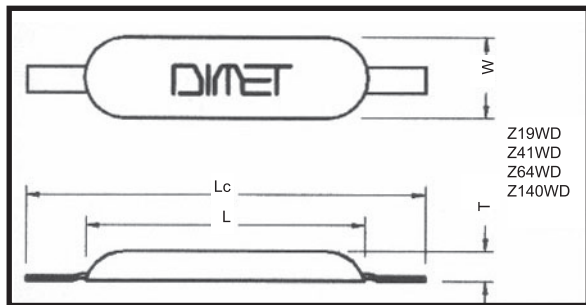
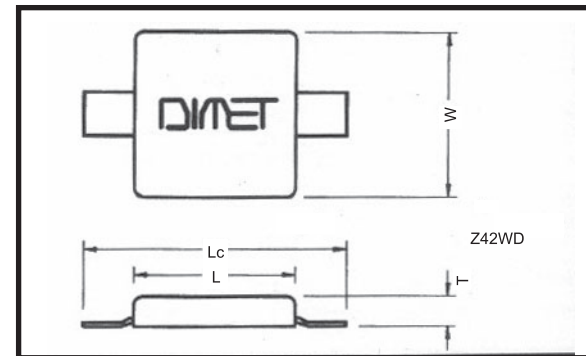
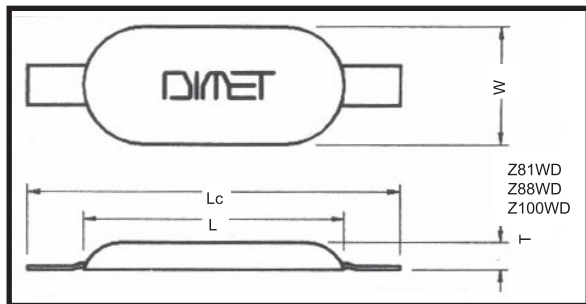

ANODE TYPE	GROSS WT (Kg)	L (mm)	W (mm)	T (mm)	Lc (mm)
Z19WD	2.1	170	75	25	230
Z41WD	4.7	305	75	38	425
Z42WD	4.5	150	150	25	230
Z64WD	7.1	305	90	45	455
Z81WD	9.0	305	152	32	455
Z88WD	9.7	305	152	35	455
Z100WD	11	305	152	38	455
Z140WD	15	456	102	53	626
Z170WD	18.5	585	134	35	750
Z200WD	21.5	585	142	40	750
Z250WD	27.5	585	142	50	750
Z350WD	37.5	585	149	67	750

NOTE: NON-STANDARD ANODES OF OTHER WEIGHTS/ DIMENSIONS OR SPECIAL CORES ARE ALSO AVAILABLE ON REQUEST

DCR TYPE

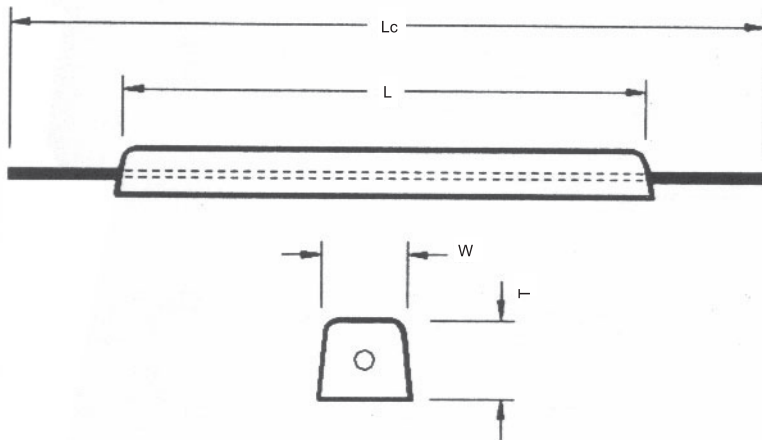
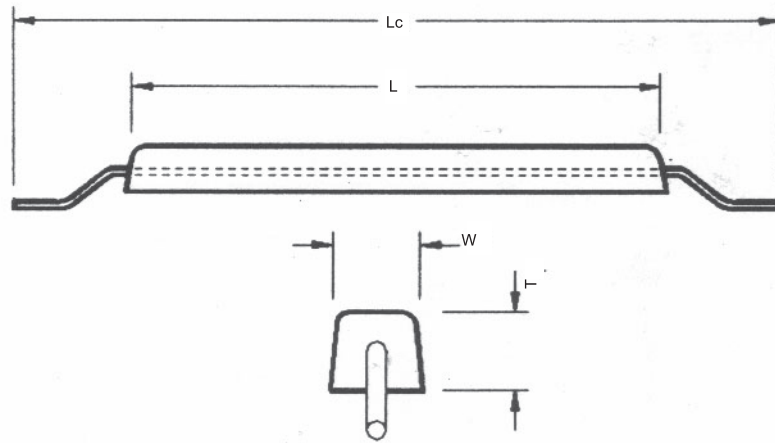

SR TYPE

ANODE TYPE SR/DCR	GROSS WT (Kg)	L (mm)	W (mm)	T (mm)	Lc (mm)
A34	5	534	44	50	830
A79	9	500	74	75	800
A82	11	1500	44	50	1800
A100	13	1500	50	50	1800
A140	17	1500	60	60	1800
A200	23	1500	70	70	1800
A250	28	1500	80	80	1800
A310	34	1500	90	90	1800

CORE TYPES

For straight rod core add suffix SR to anode type
e.g A100SR or A140SR

For double cranked rod add suffix DCR to anode type
e.g. A100DCR or A140DCR

NOTE: NON-STANDARD ANODES OF OTHER WEIGHTS/
DIMENSIONS OR SPECIAL CORES ARE ALSO
AVAILABLE ON REQUEST

DCR TYPE

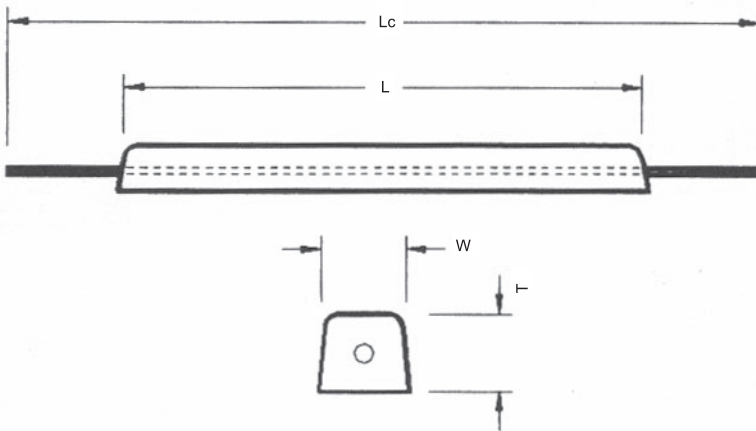
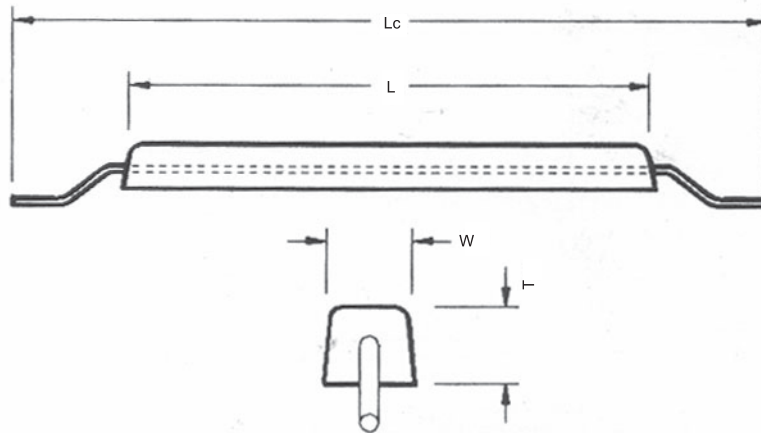

SR TYPE

ANODE TYPE SR/DCR	GROSS WT (Kg)	L (mm)	W (mm)	T (mm)	Lc (mm)
Z50	6	250	58	50	450
Z90	10	534	44	50	830
Z150	18	1500	40	40	1800
Z213	24	1500	44	50	1800
Z250	28	1500	50	50	1800
Z300	31	530	90	90	830
Z360	39	1500	60	60	1800
Z510	54	1500	70	70	1800

CORE TYPES

For straight rod core add suffix SR to anode type
e.g Z100SR or Z150SR

For double cranked rod add suffix DCR to anode type
e.g. Z100DCR or Z150DCR

NOTE: NON-STANDARD ANODES OF OTHER WEIGHTS/
DIMENSIONS OR SPECIAL CORES ARE ALSO
AVAILABLE ON REQUEST

DIMET ALUMINIUM ROD ANODES

DIMET

ANODE TYPE	WEIGHT (Kg)	LENGTH (mm)	DIAMETER (mm)
A6R	0.6	300	30
A10R	1.0	300	40
A15R	1.5	300	50
A20R	2.0	300	60
A30R	3.0	300	70
A40R	4.0	300	80
A50R	5.0	300	90
A60R	6.0	300	100
A75R	7.5	300	110
A90R	9.0	300	120
A105R	10.5	300	130

NOTE: NON-STANDARD ANODES OF OTHER WEIGHTS/DIMENSIONS OR SPECIAL CORES ARE ALSO AVAILABLE ON REQUEST

ZINC ROD ANODES

ANODE TYPE	WEIGHT (Kg)	LENGTH (mm)	DIAMETER (mm)
Z15R	1.5	300	30
Z26R	2.6	300	40
Z40R	4.0	300	50
Z60R	6.0	300	60
Z80R	8.0	300	70
Z100R	10.0	300	80
Z130R	13.0	300	90
Z160R	16.0	300	100
Z195R	19.5	300	110
Z230R	23.0	300	120
Z270R	27.0	300	130

NOTE: NON-STANDARD ANODES OF OTHER WEIGHTS/DIMENSIONS OR SPECIAL CORES ARE ALSO AVAILABLE ON REQUEST

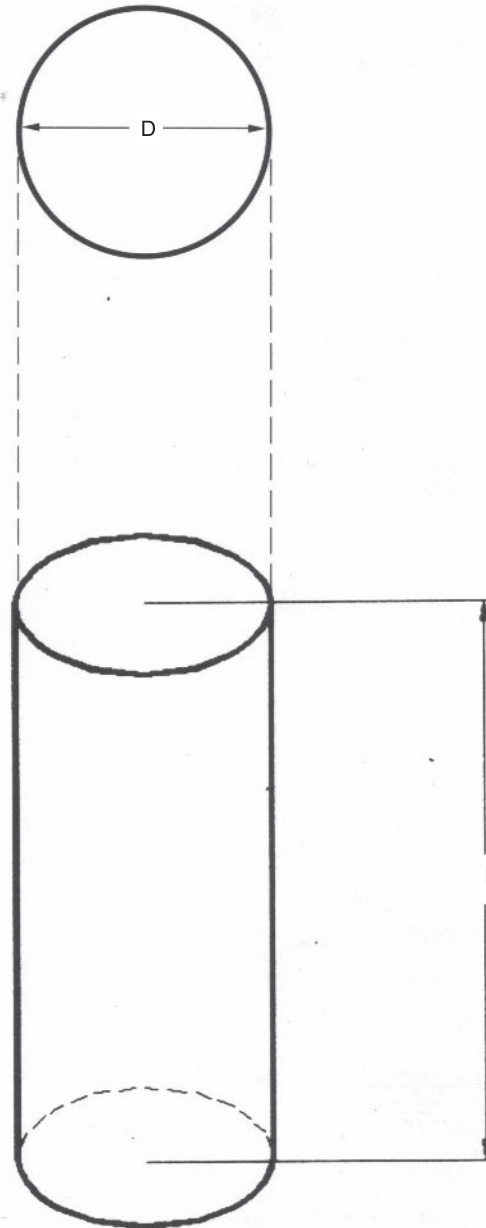

ANODE PREPACKAGED
IN COTTON BAG

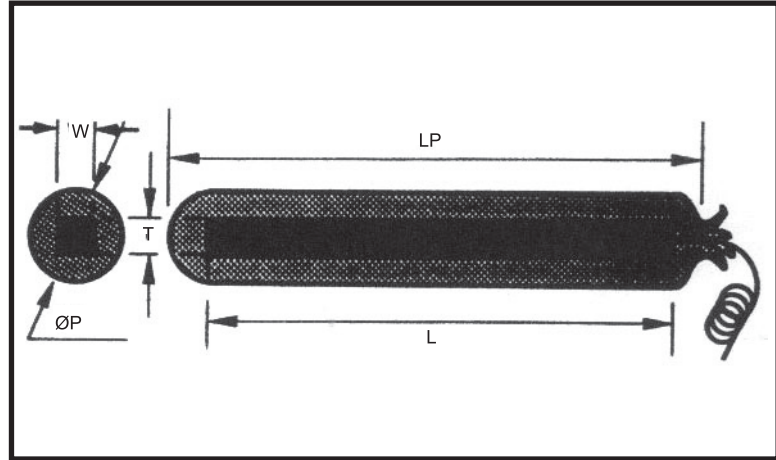

ANODE PREPACKAGED
IN FIBRE BOX

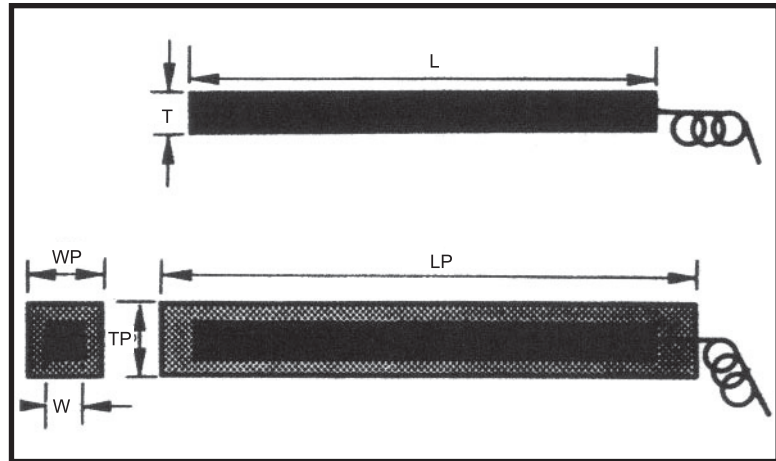

ANODE TYPE	BARE ANODE DIMENSIONS L x W x T (mm)	PREPACKAGED ANODE DIMENSIONS				NETT ALLOY WEIGHT (KG)	PREPACKAGED WEIGHT (KG)
		Lp	Wp	Tp	øp		
DM17C	660 x 89 x 89	737	–	–	165	8.0	20.5
DM20C	1524 x 63 x 63	1676	–	–	127	9.0	31.8
DM32C	533 x 127 x 127	711	–	–	203	14.5	33.6
DM48C	762 x 140 x 140	965	–	–	203	21.8	45.5
DM17F	660 x 89 x 89	508	159	159	–	8.0	20.0
DM20F	1524 x 63 x 63	1676	108	108	–	9.0	31.0
DM32F	533 x 127 x 127	546	191	191	–	14.5	33.0

SILICON/CHROMIUM/IRON IMPRESSED CURRENT ANODES

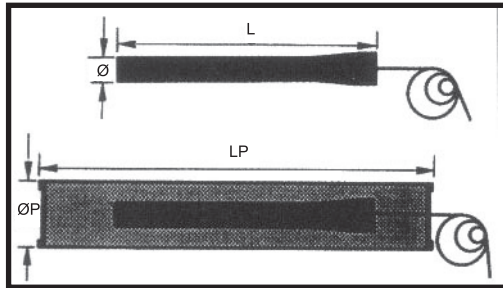
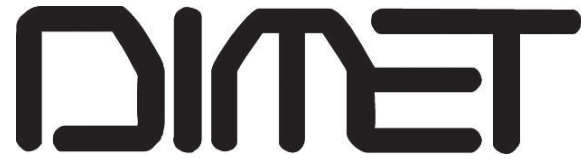

MATERIAL COMPOSITION:

Element	Weight
Silicon	14.50
Manganese	0.75
Carbon	0.95
Chromium	4.50
Iron	Balance

ANODE TYPE		NETT ANODE WT (KG)	PREPACKAGED WT (KG)	L (mm)	ø (mm)	Lp (mm)	øp (mm)
S-27	BARE	27	–	1524	50	–	–
S-50	BARE	50	–	1524	75	–	–
SP-27	PREPACKED	27	90	1524	50	2440	203
SP-50	PREPACKED	50	114	1524	75	2440	203

APPLICATIONS:

Suitable for applications in aggressive acidic or alkaline soils and seawater environment.

All anodes fitted with standard 3m x 16mm² PE/PVC copper cable. Other cables and sizes are available on request.

PLATINISED TITANIUM IMPRESSED CURRENT ANODES

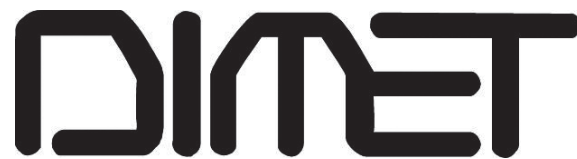

MATERIALS:

Solid titanium, niobium are available in rod, wire or mesh form. Copper cored titanium rod is also available on request. Platinum thickness in 1, 2.5, 5, 7, 10 or 12.5 microns are available.

SOLID ROD
ø mm
3
4
8
12
16
20

COPPER CORED TITANIUM ROD	
ø (mm)	WALL THICKNESS (mm)
4	0.75
8	1.5
12	2.25

TUBES	
ø (mm)	WALL THICKNESS (mm)
25.4	0.91
19.05	1.22

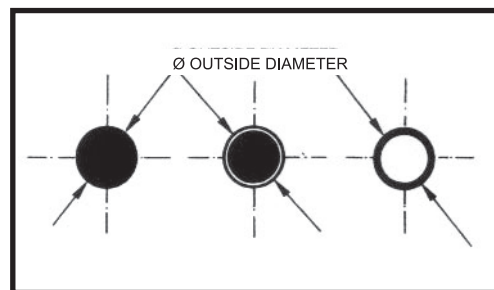

APPLICATIONS:

Water treatment plants, condenser water boxes, pipeline internals, water storage tanks, offshore platforms, deepwall groundbeds, caissons and docks, etc.

DIMET

LEAD/SILVER/ANTIMONY IMPRESSED CURRENT ANODES

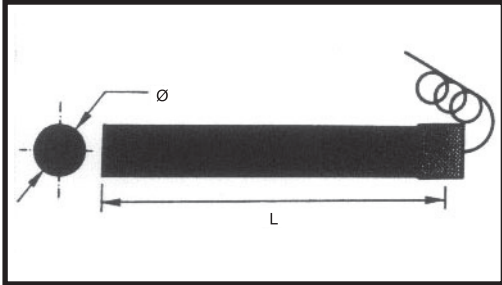

COMPOSITION:	Element	Weight (%)
	Lead	93
	Antimony	6
	Silver	1

ANODE TYPE	NETT, ALLOY WT. (KG)	L (mm)	ø (mm)
L-45	45	975	75
L-23	23	975	54

APPLICATIONS:

Suitable for wharves and jetties, offshore mobile drilling rigs and other structure in seawater.

All anodes fitted with standard 5m x 35mm² DIMET cathodic protection copper cable. Other cables such as submarine cables are available on request.

DIMET

GRAPHITE IMPRESSED CURRENT ANODES

MATERIALS:

Graphite anode is available either in plain or impregnated with linseed oil.

ANODE TYPE	NETT, ANODE WT. (KG)	PREPACKAGED WT (KG)	L (mm)	ø (mm)	Lp (mm)	øp (mm)
BARE G-11	11	-	1524	75	-	-
PREPACKAGED GP-11	11	75	1524	75	2440	100

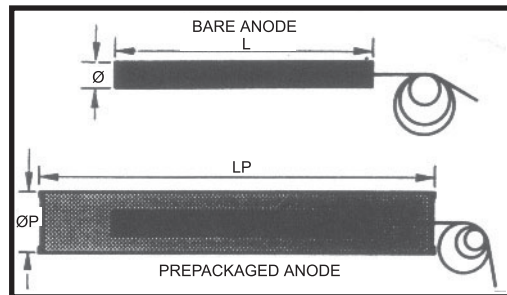

APPLICATIONS:

For onshore pipelines and structure. Oil impregnated graphite anodes would be used for offshore application.

OIL COOLED RECTIFIERS

DIMET

THE "CUSTOM" LINE

Our custom made Cathodic Protection Rectifiers are the finest in the world. Our reputation for excellence is based on generous design, high quality components and craftsmanship in construction. Highly efficient, light weight and compact, they are easy to install and maintain and are built for years of rugged service. Where premium rectifiers in critical locations are a design requirement, specify DIMET rectifiers.

CUSTOM OIL For Extreme Environments

A heavy-duty oil-immersed oil-cooled rectifier which is especially suited for use in areas where dust, salt air, corrosive fumes, or excessive moisture may cause short life for air-cooled type.

CUSTOM EXPLOSION PROOF For Class I, Group D Environments

A modified Custom-Oil Rectifier supplied with explosion-proof fittings required by code for use in refineries, chemical plants, and other areas where explosive or flammable vapors, liquids or powders may be present.

CUSTOM OIL CUSTOM EXPLOSION PROOF-OIL SPECIAL CABINET FEATURES

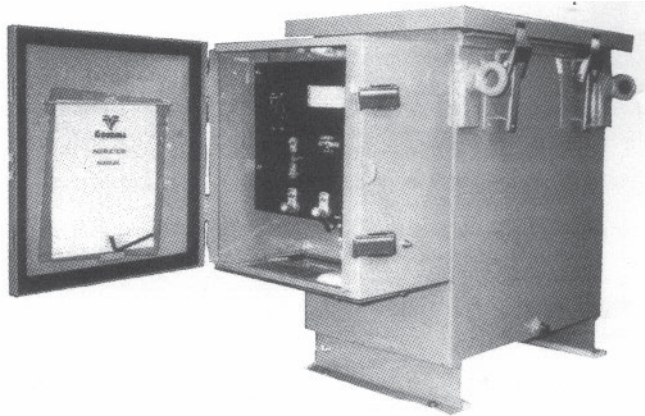

ORDER CODE

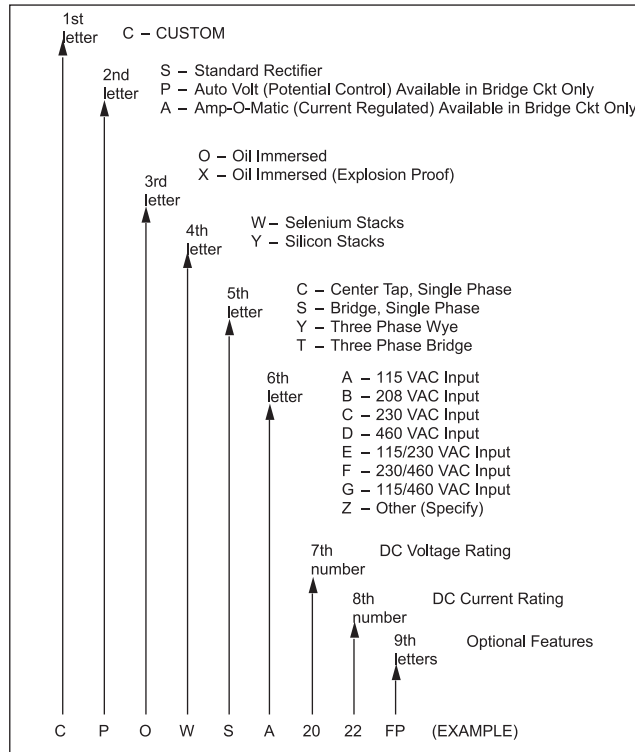

OPTIONAL FEATURES

Any of these features available for Custom-Oil Rectifiers

- B - Bolt top
- C - Cross Arm mounting
- E - Continuous reading meters
- F - Noise interference filter
- G - Efficiency filter
- H - Other than standard number of DC Output steps (standard has 20 steps) (specify)
- J - Flashing signal light (Continuous at normal current, flashing at undercurrent, out at loss of input)
- K - Continuous signal light (Out at loss of input, output or at undercurrent)
- L - Lightning protection for AC input only
- M - Lightning protection for DC output only
- N - Lightning protection for both input and output
- P - Special finishes (specify)
- Q - Export crating
- R - Interrupter Circuit
- T - Higher ambient temperatures (specify)
- V - Non standard access fittings (specify)
- Y - Input frequency other than 60 cycle (specify)
- Z - Any other features (specify)

TRANSFORMER RECTIFIERS

DIMET

OIL COOLED RECTIFIERS

TRANSFORMER RECTIFIERS

CUSTOM OIL TANK

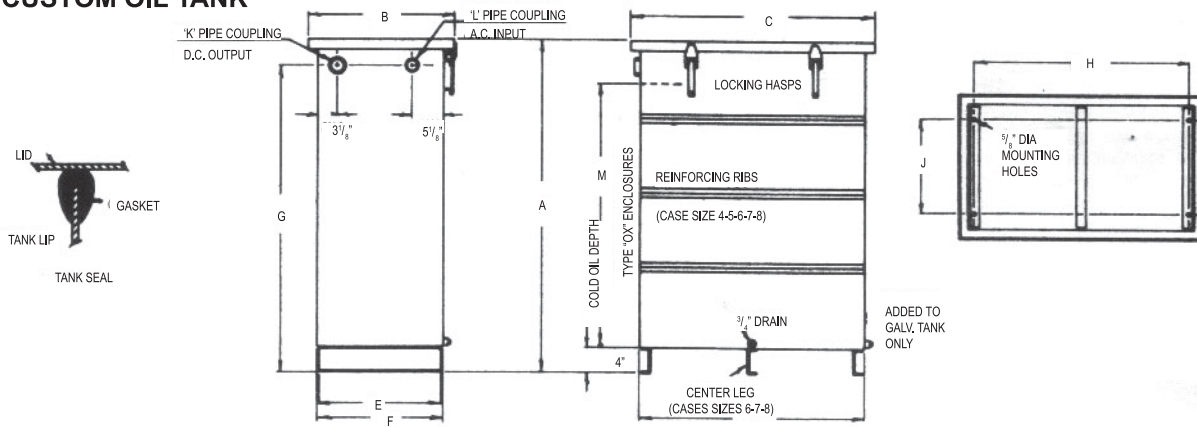

SIZE	A	B	C	D	E	F	G	H	J	K	L	MAX. GAL. OIL	M*
0-1	31 ⁷ / ₁₆	19 ¹ / ₄	27 ¹ / ₄	24 ¹ / ₄	16	16 ¹ / ₄	27 ³ / ₄	23	12	1 ¹ / ₂	1	36	21 ¹ / ₂
0-2	34 ⁷ / ₁₆	19 ¹ / ₄	33 ¹ / ₄	30 ¹ / ₄	16	16 ¹ / ₄	30 ³ / ₄	29	12	1 ¹ / ₂	1	51	24 ¹ / ₂
0-3	40 ⁷ / ₁₆	21 ¹ / ₄	39 ¹ / ₄	36 ¹ / ₄	18	18 ¹ / ₄	36 ³ / ₄	35	14	1 ¹ / ₂	1	84	30
0-4	53 ⁷ / ₁₆	23 ¹ / ₄	39 ¹ / ₄	36 ¹ / ₄	20	20 ¹ / ₄	49 ³ / ₄	35	16	2	1	132	42 ¹ / ₈
0-5	56 ⁷ / ₁₆	23 ¹ / ₄	51 ¹ / ₄	48 ¹ / ₄	20	20 ¹ / ₄	52 ³ / ₄	47	16	2	1 ¹ / ₂	186	44 ⁷ / ₈
0-6	58 ⁷ / ₈	23 ¹ / ₄	63 ¹ / ₄	60 ¹ / ₄	20	20 ¹ / ₄	54 ¹ / ₈	59	16	2 ¹ / ₂	1 ¹ / ₂	241	46 ³ / ₈
0-7	61 ⁷ / ₁₆	25 ¹ / ₄	75 ¹ / ₄	72 ¹ / ₄	22	22 ¹ / ₄	57 ¹ / ₈	71	18	2 ¹ / ₂	1 ¹ / ₂	337	49 ¹ / ₈
0-8	68 ⁷ / ₁₆	25 ¹ / ₄	75 ¹ / ₄	72 ¹ / ₄	22	22 ¹ / ₄	63 ³ / ₄	71	18	3	1 ¹ / ₂	380	55 ³ / ₈

*LESS 2" IN TYPE "O" ENCLOSURES

CUSTOM EXPLOSION PROOF OIL TANK ASSEMBLY

1. MAIN PANEL
2. OIL LEVEL GAUGE
3. SEALING CONDULET
4. METER
5. CIRCUIT BREAKER
6. DRAIN

	OX1	OX2	OX3	OX4	OX5	OX6	OX7	OX8
X	7 ¹⁵ / ₁₆	10 ¹⁵ / ₁₆	16 ¹⁵ / ₁₆	21 ⁵ / ₈	24 ³ / ₈	28 ³ / ₈	29 ³ / ₈	36

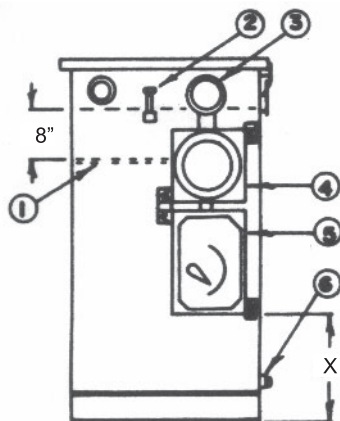

EXPLOSION PROOF
OX1 - OX4

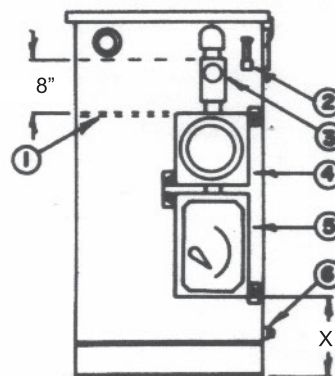

EXPLOSION PROOF
OX5 - OX8

Tables are intended as a guideline only - consult Tri-Star for exact case size and weight.

AIR COOLED RECTIFIERS

DIMET

THE "CUSTOM" LINE

Our custom made Cathodic Protection Rectifiers are the finest in the world. Our reputation for excellence is based on generous design, high quality components and craftsmanship in construction. Highly efficient, light weight and compact, they are easy to install and maintain and are built for years of rugged service. Where premium rectifiers in critical locations are a design requirement, specify DIMET rectifiers.

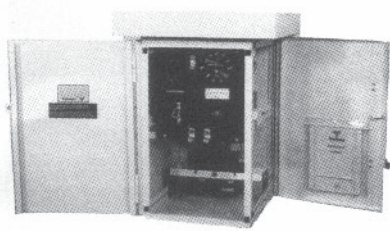

CUSTOM-AIR

Sets the standard for the industry.

- Attractive appearance – lightweight, compact.
- Welded frame with sturdy 16-gauge top, sides, and front.
- Small-arms-proof 11-gauge sides, back, and front optional.
- Double thickness 11 gauge front, sides and back available for extra protection (A-1 thru A-8).
- Convenient enclosure – top quickly removable front and side doors with lift-off hinges. (A-1 thru A-4), single front door. (A-5 thru A-8), double front doors.
- Easy access to components for cleaning and servicing.
- Combination pole-wall mounting is standard (A-1 thru A-4).
- Cross-arm or pedestal mounting is optional. (A-1 thru A-4).
- Pedestal mtg. standard. (A-5 thru A-8).
- Aluminium cabinet available (A-1 thru A-4).
- Stainless cabinet available (A-1 thru A-8).

CUSTOM-AS

EQUIPPED WITH SLIDE-OUT RACKS. (AS-1 thru AS-4)

- Slide-out racks for convenience of servicing.
- Welded frame with sturdy 16-gauge top, sides, and front.
- Small-arms-proof 11-gauge sides, back, and front optional.
- Double thickness 11-gauge front, sides and back available for extra protection. (AS-1 thru AS-4).
- Same mounting dimensions as regular Custom-Air with same front and side doors and top.
- Combination pole-wall mounting is standard.
- Cross-arm or pedestal mounting is optional.
- Remove racks – lift off doors, for easy lifting of case to the pole for installation.
- Interchangeability of component racks with other like units.
- Aluminium cabinet available (AS-1 thru AS-4).
- Stainless cabinet available (AS-1 thru AS-4).

ORDER CODE

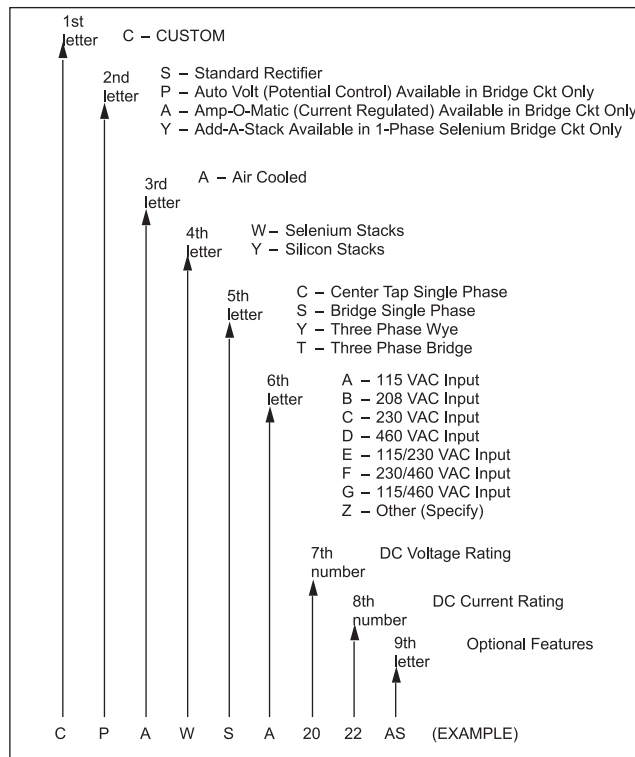

OPTIONAL FEATURES

Any of these features available for Custom-Air Rectifiers (Symbol designates features available on † Add-A-Stack rectifiers)

- A – Slide out racks for transformer & stack
- † C – Cross Arm mounting
- † D – Legs (specify) air cooled 10" standard
- E – Continuous reading meters
- F – Noise interference filter
- G – Efficiency filter
- H – Other than standard number of DC Output steps (standard has 20 steps) (specify)
Add-A-Stack standard has 36
- J – Flashing signal light (Continuous at normal current, flashing at undercurrent, out at loss of input)
- K – Continuous signal light (Out at loss of input, output or at undercurrent)
- † L – Lightning protection for AC input only
- † M – Lightning protection for DC output only
- † N – Lightning protection for both input and output
- † P – Special finishes (specify)
- † Q – Export crating
- R – Interrupter Circuit
- † S – Small arms proof (11 gauge front, side and back)
- T – Higher ambient temperatures (specify)
- † V – Non standard access knockouts (specify)
- Y – Input frequency other than 60 cycle (specify)
- Z – Any other features (specify)

DIMET

AIR COOLED RECTIFIERS

TRANSFORMER RECTIFIERS

A-1 THRU A-4 CASE

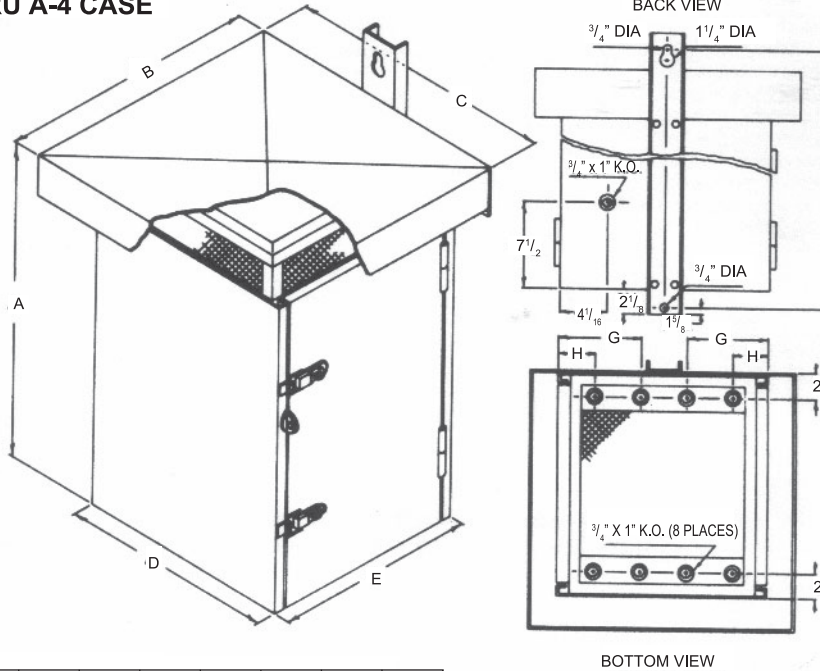

SIZE	A	B	C	D	E	F	G	H
A-1	21 ⁹ / ₁₆	15 ¹ / ₈	18 ¹ / ₈	14 ⁷ / ₈	13 ¹ / ₈	26	6 ¹ / ₂	4 ⁵ / ₁₆
A-2	30 ⁹ / ₁₆	22 ³ / ₈	23 ³ / ₁₆	18 ¹ / ₂	19 ¹ / ₈	34	8 ⁵ / ₁₆	4 ⁵ / ₁₆
A-3	30 ⁹ / ₁₆	22 ³ / ₈	29 ³ / ₈	24 ³ / ₄	19 ¹ / ₈	34	11 ⁷ / ₁₆	7 ¹¹ / ₁₆
A-4	41 ⁹ / ₁₆	22 ³ / ₈	29 ³ / ₈	24 ³ / ₄	19 ¹ / ₈	46	11 ⁷ / ₁₆	7 ¹¹ / ₁₆

A-5 THRU A-8 CASE

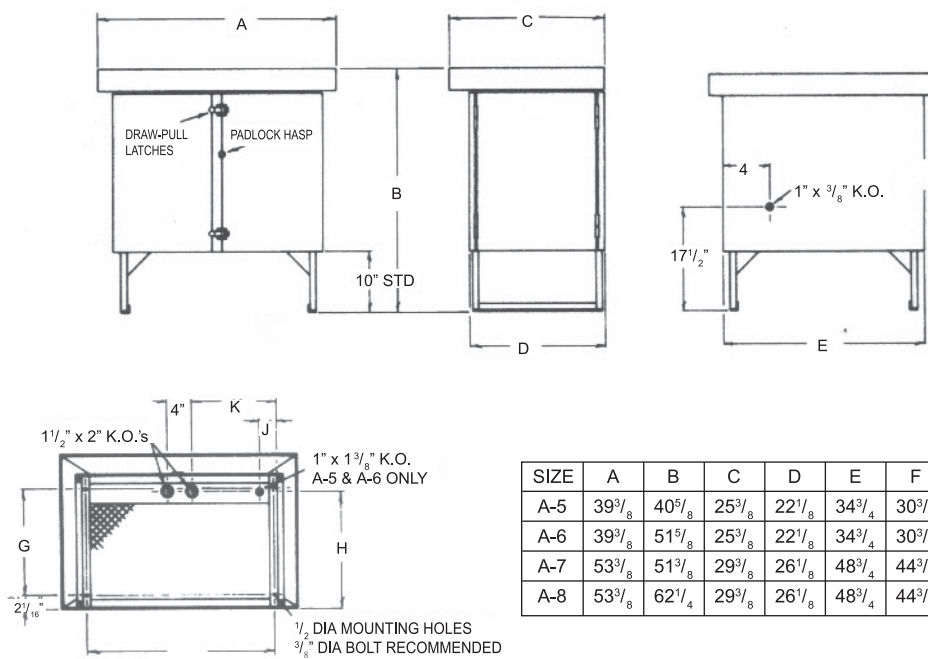

SIZE	A	B	C	D	E	F	G	H	J	K
A-5	39 ³ / ₈	40 ⁵ / ₈	25 ³ / ₈	22 ¹ / ₈	34 ³ / ₄	30 ³ / ₄	18	19 ¹ / ₂	2 ⁷ / ₈	14 ¹ / ₄
A-6	39 ³ / ₈	51 ⁵ / ₈	25 ³ / ₈	22 ¹ / ₈	34 ³ / ₄	30 ³ / ₄	18	19 ¹ / ₂	2 ⁷ / ₈	14 ¹ / ₄
A-7	53 ³ / ₈	51 ³ / ₈	29 ³ / ₈	26 ¹ / ₈	48 ³ / ₄	44 ³ / ₄	22	23 ¹ / ₂	0	21 ¹ / ₄
A-8	53 ³ / ₈	62 ¹ / ₄	29 ³ / ₈	26 ¹ / ₈	48 ³ / ₄	44 ³ / ₄	22	23 ¹ / ₂	0	21 ¹ / ₄

Tables are intended as a guideline only – consult Tri-Star for exact case size and weight.

AUTOMATIC CONTROL RECTIFIERS

DIMET

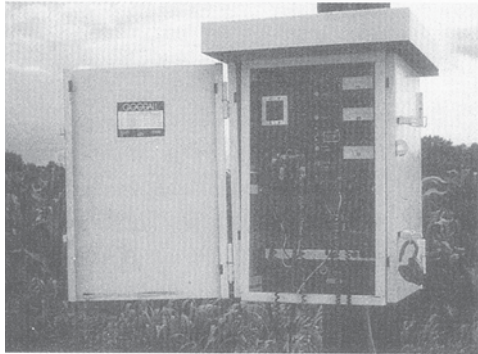

- V VOLTAGE REGULATED**
 VOLTAGE ADJUSTED BY A SMALL 1/10 WATT POTENTIOMETER
 LINK BARS AND TAP SWITCHES ARE NOW OLD FASHIONED.
 ELECTRONIC CURRENT LIMIT IS A STANDARD FEATURE.
- I CURRENT REGULATED**
 OUTPUT CURRENT WILL VARY NO MORE THAN 1% WHEN ANODE
 CIRCUIT RESISTANCE CHANGES FROM 100% TO 0%
 ELECTRONIC VOLTAGE LIMIT IS A STANDARD FEATURE.
- P POTENTIAL CONTROL**
 AUTOMATIC POTENTIAL CONTROL MAY BE ACHIEVED BY THE
 ADDITION OF A SMALL PRINTED CIRCUIT CARD CONTROLLER
 ELECTRONIC VOLTAGE AND CURRENT LIMITS ARE STANDARD
 FEATURES.

ORDER CODE

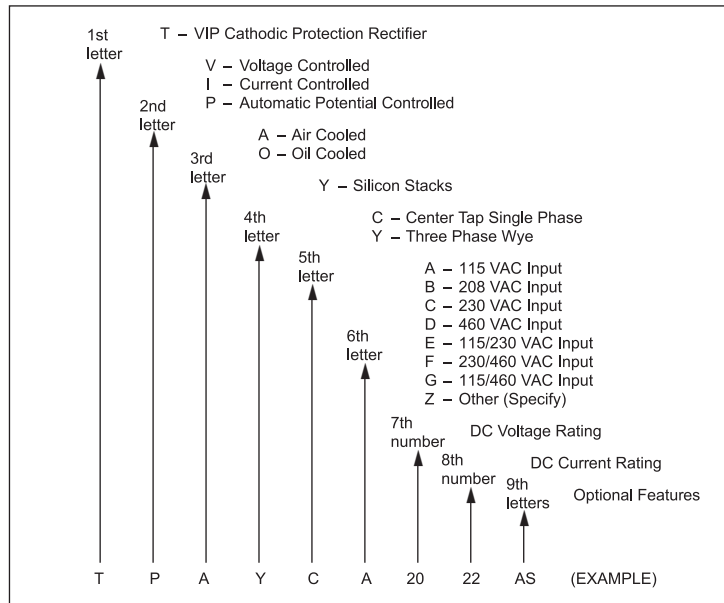

OPTIONAL FEATURES

- Any of these features available
- A – Slide out racks for transformer & stack
 - † C – Cross Arm mounting
 - † D – Legs (specify) air cooled 10" standard
 - E – Continuous reading meters
 - F – Noise interference filter
 - G – Efficiency filter
 - J – Flashing signal light (Continuous at normal current, flashing at undercurrent, out at loss of input)
 - K – Continuous signal light (Out at loss of input, output or at undercurrent)
 - † N – Lightning protection for both input and output
 - † P – Special finishes (specify)
 - † Q – Export crating
 - R – Interrupter Circuit
 - † S – Small arms proof (11 gauge front, side and back)
 - T – Higher ambient temperatures (specify)
 - † V – Non standard access knockouts (specify)
 - Y – Input frequency other than 60 cycle (specify)
 - Z – Any other features (specify)

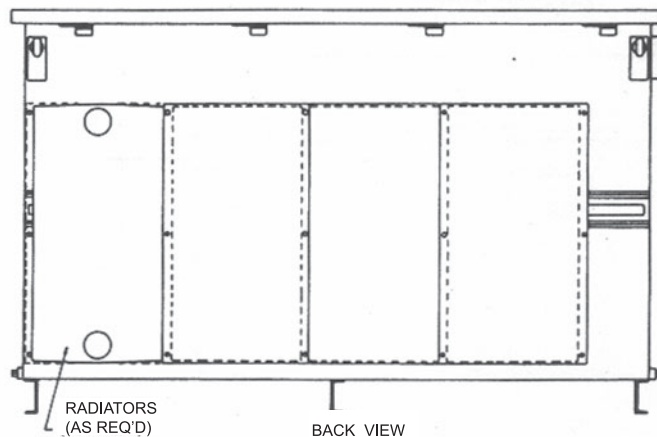
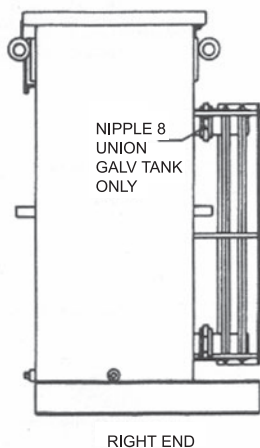
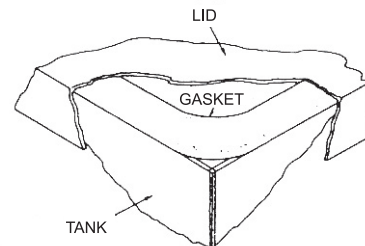

TRANSFORMER RECTIFIERS

DIMET

AUTOMATIC CONTROL RECTIFIERS



TRANSFORMER RECTIFIERS



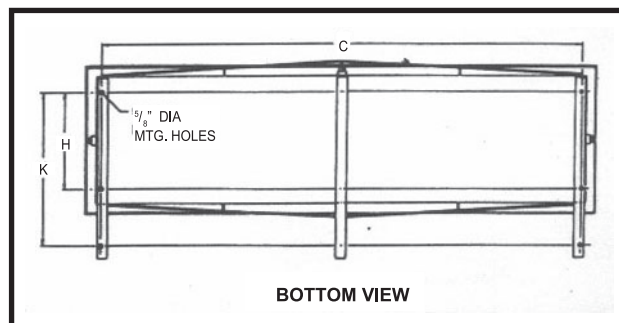
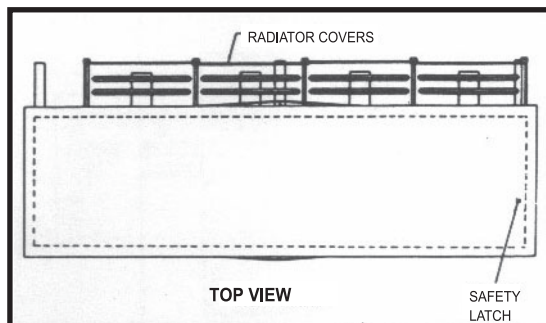
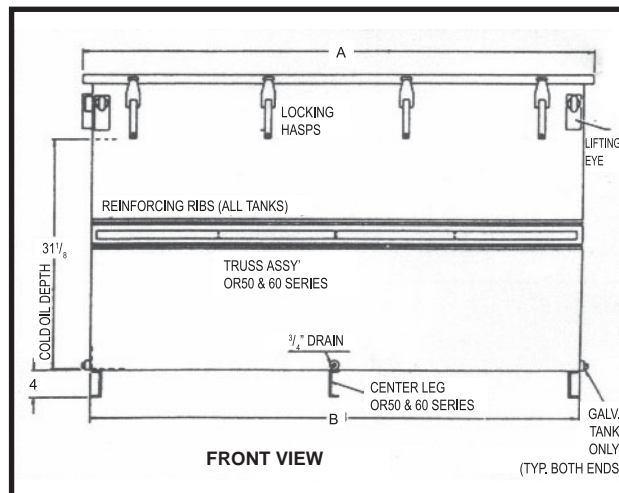
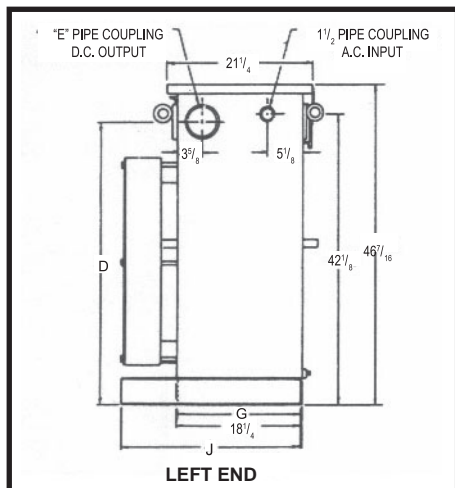

TANK	MAX GALS OIL*	RADIATORS	A	B	C	D	E	G	H	J	K
OR20	58.2	0	27 ¹ / ₄	24 ¹ / ₄	23	42 ¹ / ₈	2 ¹ / ₂	18	14		
OR21	59.8	1	27 ¹ / ₄	24 ¹ / ₄	23	42 ¹ / ₈	2 ¹ / ₂			28	22
OR30	87.3	0	39 ¹ / ₄	36 ¹ / ₄	35	42 ¹ / ₈	2 ¹ / ₂	18	14		
OR31	88.9	1	39 ¹ / ₄	36 ¹ / ₄	35	42 ¹ / ₈	2 ¹ / ₂			28	22
OR32	90.5	2	39 ¹ / ₄	36 ¹ / ₄	35	41 ³ / ₄	3			28	22
OR40	116.4	0	51 ¹ / ₄	48 ¹ / ₄	47	41 ³ / ₄	3	18	14		
OR41	118.0	1	51 ¹ / ₄	48 ¹ / ₄	47	41 ³ / ₄	3			28	22
OR42	119.6	2	51 ¹ / ₄	48 ¹ / ₄	47	41 ⁷ / ₁₆	3 ¹ / ₂			28	22
OR50	145.5	0	63 ¹ / ₄	60 ¹ / ₄	59	41 ⁷ / ₁₆	3 ¹ / ₂	18	14		
OR51	147.1	1	63 ¹ / ₄	60 ¹ / ₄	59	41 ⁷ / ₁₆	3 ¹ / ₂			28	22
OR52	148.7	2	63 ¹ / ₄	60 ¹ / ₄	59	41 ⁷ / ₁₆	3 ¹ / ₂			28	22
OR53	150.3	3	63 ¹ / ₄	60 ¹ / ₄	59	41 ¹ / ₄	4			28	22
OR60	174.6	0	75 ¹ / ₄	72 ¹ / ₄	71	41 ¹ / ₄	4	18	14		
OR61	176.2	1	75 ¹ / ₄	72 ¹ / ₄	71	41 ¹ / ₄	4			28	22
OR62	177.8	2	75 ¹ / ₄	72 ¹ / ₄	71	41 ¹ / ₄	4			28	22
OR63	179.4	3	75 ¹ / ₄	72 ¹ / ₄	71	41 ¹ / ₄	4			28	22
OR64	181.0	4	75 ¹ / ₄	72 ¹ / ₄	71	41 ¹ / ₄	4			28	22

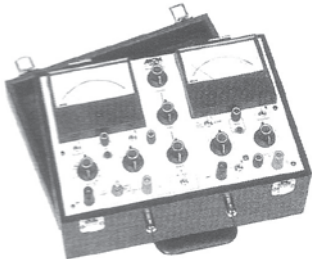
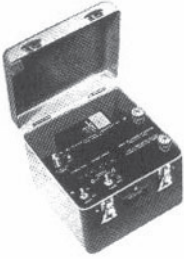
* ACTUAL GALS WILL BE LESS WITH INTERNAL TANK COMPONENTS.

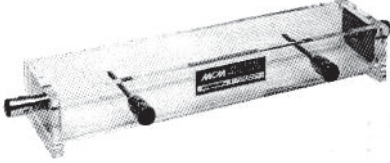
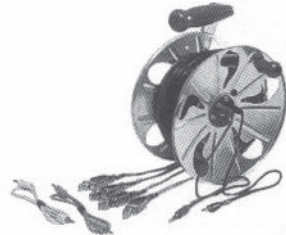

Tables are intended as a guideline only – consult Tri-Star for exact case size and weight.

MODEL NO.	DESCRIPTION
B3A2	 <p>M.C. MILLER MULTIMETER</p>
M-3-A2	 <p>M.C. MILLER MULTIMETER</p>
N-820	 <p>NILSSON CURRENT INTERRUPTER</p>
N-400	 <p>NILSSON SOIL RESISTANCE METER</p>
N-715	 <p>NILSSON PIPE AND CABLE LOCATOR</p>

MODEL NO.	DESCRIPTION
SRC	 <p>SILVER/SILVER CHLORIDE REFERENCE ELECTRODE</p>
RE-5	 <p>COPPER/COPPER SULPHATE REFERENCE ELECTRODE</p>
SB	 <p>SOIL BOX</p>
AR-8	 <p>AGRA REEL C/W CABLE AND SUBMERSIBLE ADAPTOR</p>
LC-4	 <p>M.C. MILLER LC-4 CORROSION VOLTMETER</p>



MODEL NO.	DESCRIPTION
B-3-D	M.C. Miller digital multi combination meter
M-3-A1	M.C. Miller standard multi combination meter
PM-6002	M.C. Miller standard strip chart recorder
RE-3A	Copper sulphate reference electrode
RE-5C	Copper sulphate reference electrode
RE-7	Copper sulphate reference electrode
CS-5	Current measurement shunt 5 amps.
CS-10	Current measurement shunt 10 amps.
CS-15	Current measurement shunt 15 amps.
CS-25	Current measurement shunt 25 amps.
CS-50	Current measurement shunt 50 amps.
CS-100	Current measurement shunt 100 amps.
CS-200	Current measurement shunt 200 amps.
SB-7008	Soil box
K-5	Kirk cell
K-50	Kirk cell
DJB-4	DIMET cast aluminium junction box 4" diameter
DJB-6	DIMET cast aluminium junction box 6" diameter
DJB-10	4 1/2" x 8 1/2"
TP-4	DIMET test point c/w 4" diameter junction box and stand
TP-6	DIMET test point c/w 6" diameter junction box and stand

OTHERS

PSI Flange Insulation Gaskets, Sleeves and Washers

GasketSeal Gaskets

LineBacker Gaskets

Neoprene Faced Phenolic Gaskets

Plain Phenolic Gaskets

SPECIFICATION SHEET FOR STEEL PILE PROTECTION

PURPOSE

To control corrosion of steel piling.

PRINCIPLE

PILE-GARD® barriers create a tight envelope around the pile isolating the pile from its environment. Oxygen is rapidly depleted from the water in this trapped space and the rate of corrosion is sharply reduced or stopped altogether, depending on the quality of seal obtained. Careful installation techniques will result in a hermetic seal where corrosion cannot continue.

DIAGRAM (below)

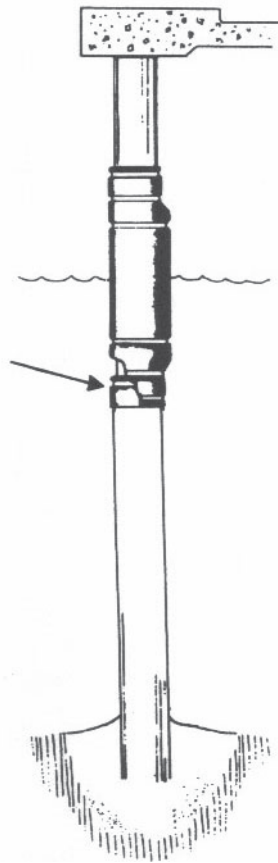

BILL OF MATERIALS

(a) PILE-GARD® manufactured units are available in modular lengths of 4', 6', 8', 10', 12', 14' and 16'. Widths are available as required by design. Seal Kits with all accessory materials and hardware are provided.

1. **Intertidal Units** – Hydraulic seals are required at the intertidal zone to eliminate pumping action and oxygen replacement within the barrier due to rise and fall of the tides.
2. **Subtidal Units** – Hydraulic seals are required at each overlapped section. A 6" minimum overlap is required.
3. Pile-Gard® wraps for steel application have a standard thickness of .060".

METHOD

1. Make detailed and full length inspection of each pile.
2. Wrap sequence and configuration shall be designed to accommodate conditions encountered.
3. Select piles to be wrapped and remove all surface growths and protrusions that might strain or damage the wrap. Do not remove existing corrosion.
4. Install intertidal barrier with top and bottom seals and/or submerged section as required.

SPECIFICATION OF PILE-GARD SYSTEM COMPONENTS (A PATENTED SYSTEM)

Pile-Gard system components include special formulated polyvinyl chloride wrappers, the wooden pole pieces used for vertical stiffening and manipulation, the bands for securing the wraps and foam sealant for creating hermetic seals at the upper and lower ends of each module.

ENCAPSULATION SYSTEM FLEXIBLE WRAPPER

The flexible wrapper for encapsulation shall be a specially formulated polyvinyl chloride (be able to resist aging and ultra violet light). It shall be new, non-rigid homopolymer material. The wrap material shall be uniform throughout; free from dirt, oil and other foreign matter and free from cracks, creases, bubbles, pits, tears, holes and any defects that may affect its service. The properties of the flexible PVC wrapper shall conform to the following specification:

Properties	Requirement	ASTM Test Method
Thickness (ins)	0.060 plus minus 0.005	D-792
Specific Gravity	1.2 plus minus 10%	D-882 (Method A)
Tensile Strength (psi)	MD 2500 min TD 2000 min	D-882
100% Modulus (psi)	MD 1700 max TD 1700 max	D-882
Ultimate Elongation (%)	MD 300 min TD 300 min	D-882
Low Temperature Impact	6 pass, -20% pass	D-1790
Volatility (% loss @ 70 deg C for 24 hours)	1.5% max	D-1203
Graves Tear (lb/in)	MD 300 min TD 300 min	D-1004
Shrinkage (%)	MD 5.0% max TD 5.0% max	D-1204
Water Extraction, % Loss @ 23 deg C for 7 days	0.75% max	D-543 (Method I)

DIMET

Pile-Gard SYSTEM

SPECIFICATION SHEET FOR STEEL PILE PROTECTION

BANDING METAL

The banding strap shall be of 24 gauge by one inch wide aluminium alloy 5052, H-34 work hardened. This strap is used to secure the wraps. Sufficient length of this strap shall be provided to encircle completely the pile over the sealed area.

POLE PIECES

A one inch half-round selected heart grade apitong shall be used for vertical stiffening and manipulation. It shall be able to resist the stress of wrapping procedure. In order to provide a 12 inch (30 cm) long PVC skirt at each end, the length of each pole piece shall be a 2 feet (609 mm) shorter than the length of the flexible wrap.

SEALANT

Two lengths of $\frac{3}{8}$ " (9.5 mm) by 1.5" (38.1 mm) self-adhesion foam shall be used as sealant to provide a water tight envelope at the top and bottom sections of the flexible wrap.

INSTALLATION OF PILE-GARD SYSTEM

The installation of the Pile-Gard system must be carried out by Tri-Star authorised contractor and shall not cause any downtime in the Pier/Jetty operation.

Little surface preparation work is required for the application of the Pile-Gard system. The surface cleaning may be done manually or with mechanised equipment. Only the surface growths and protrusions that might strain or damage the wraps need to be removed from pile splash zone area. The existing corrosion product will be left untouched on the pile surface.

The pile shall be encircled with PVC wrappers which are stiffened by rigid longitudinal pole pieces. The pole pieces are mated and rolled up by means of a ratchet wrench to provide a tight fitting encasement that creates a hermetic seal around the pile. The module is secured to the pile by aluminium bands.



MARINE PILING PETROLATUM PASTE

DESCRIPTION

Marine Piling Petrolatum Paste is a petrolatum based compound. It is a soft beige paste which may be applied underwater by gloved hand, stiff bristle brush or roller.

USE

Marine Piling Petrolatum Paste is designed for the preparation of metal surface underwater prior to the application of Marine Piling Petrolatum Tape. It deposits a layer of protective compound onto the surface such that water is displaced and voids filled when the tape is applied.

PROPERTIES

	UNIT	VALUE
Specific gravity	g/cm ³	1.08
Specific volume	cm ³ /kg	925
Coverage	m ² /kg	2.5
Temperature range: For wrapping In service – maximum		0 to +70°C 70°C

PACKING

25 kg drum

STORAGE

Should be stored in original drums until required for use. Store in a dry, cool well ventilated condition out of direct sunlight and other major sources of heat. Stock should be rotated on a first in/first out basis.



MARINE PILING PETROLATUM TAPE

DESCRIPTION

A highly conformable anti-corrosion tape that is wound onto wet surfaces. Similar in characteristics and construction to normal petrolatum tape but with added inhibitors and water displacing agent.

USES

Marine piling tape is designed for use in the anti-corrosion protection of tubular and box marine piles and offshore riser pipes, particularly in the aggressive tidal and splash zones where pipes are constantly wet.

BENEFITS

- Non demanding surface preparation
- For use on new or corroded metal
- Easy application below or above water

SURFACE PREPARATION

Substrate should be as clean as possible. Remove all loose matter, dirt and mill scale.

TYPICAL PROPERTIES

	UNIT	VALUE
Total tape thickness	mm	1.30
Weight	kg.m ²	1.62
Tape strength	kg/25mm width	10
Breakdown voltage	double layer	16 Kv
Elongation	%+	12
Temperature range: For wrapping In service – maximum	°C °C	0 to +70 70

PACKING

Marine Piling Tape Roll sizes:

Length – 10 metres

Width – 50, 75, 100, 150 mm or to order

STORAGE

Petrolatum

Should be stored in original cartons until required for use. Store in a dry, cool, well ventilated condition out of direct sunlight and other major sources of heat. The cartons should not be stacked more than 3 high and pallets not more than 2 high. Stock should be rotated on a first in/first out basis.



FRP JACKET SYSTEM

MARINE PILING FRP COVER

DESCRIPTION

Mixing with quick curing type polyester resin and fibreglass for hand lay-up and spray on moulding, the FRP cover provides a strong physical barrier between the inside petrolatum paste & tape and external forces. This maintains the corrosion protecting effect for the long term and protects facilities from corrosion.

USE

Combined with Formed Polyethylene to provide protective wrapping/jacket system against corrosion.

1. PROPERTIES OF LIQUID RESIN

	UNIT	VALUE
Viscosity at 25°C	poise	5.0 – 6.0
Volatile Content	%	38
Gel Time at 25°C	minimum	16-25
P.E. Temperature	°C	110

2. PROPERTIES OF MAT CAMINATE OF 34.3% GLASS CONTENT

	UNIT	DRY	WET
Flexural Strength	kg +/cm ²	2593	2550
Flexural Modulus	kg +/cm ²	109777	97628
Tensile Strength	kg +/cm ²	1357	1399
Tensile Modulus	kg +/cm ²	118096	98339

MARINE PILING FORMED POLYETHYLENE

DESCRIPTION

Marine Piling Formed Polyethylene is part of the FRP jacket system. It is a foamed synthetic resin that absorbs external shock. Further, this foamed synthetic resin presses evenly on the corrosion protection coating layers even if the steel surface is uneven.

USE

Combined with FRP cover as a protective wrapping/jacket system against corrosion in the splash zones.

PROPERTIES

	UNIT	VALUE
Density	PCF	1 – 7
Density range curved	PCF	1.6 ~ 1.9
Cell size	mm	1.5 ~ 1.9
Compression strength – 10% deflection – 25% deflection – 50% deflection	PSI	3.75 6.50 15.00
Compression set	%	18.5
Tensile strength	PSI	40
Tensile elongation	%	115
Tear strength	lb/in	12
Compression creep	% deflection	C4
Buoyancy	PCF	58

ANODE MANUFACTURING FLOW CHART

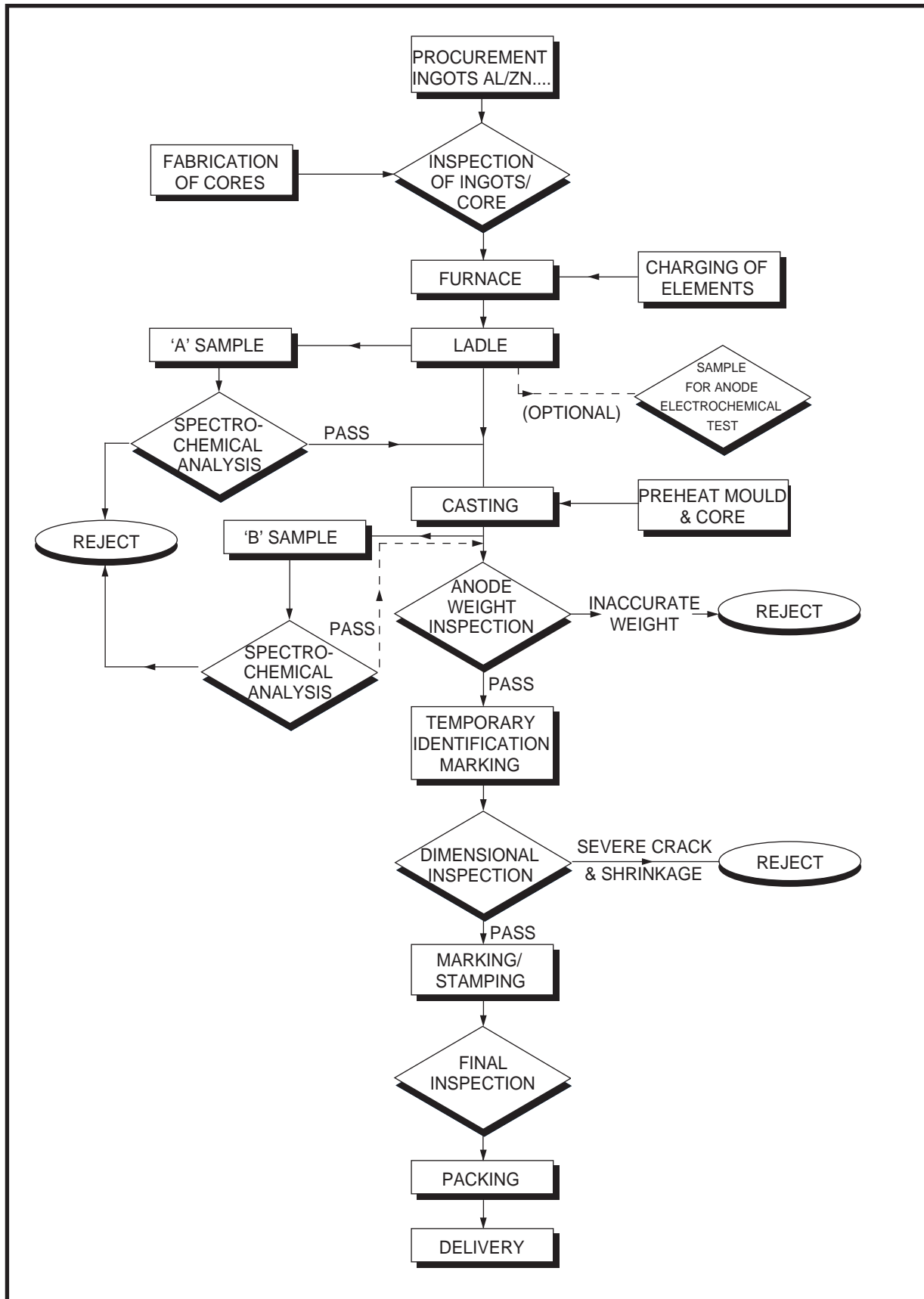

Similar Quality Assurance Procedures are in place for the other Cathodic Protection and Corrosion Prevention Products.

MALAYSIA OFFICES :-

**SBN INDUSTRIES SDN BHD
HEADQUARTERS (HQ)**

6, Jalan Penaga, Kawasan Perindustrian Kota Putri,
81750 Masai, Johor , West Malaysia

Tel +60 7 388 2521

Fax +60 7 388 2523

Email sales@sbnbiz.com

Web www.sbnbiz.com

KL OFFICE

Unit 13A-2, Pangsapuri Servis, (Suite) Binjai 8,
No. 2, Lorong Binjai, 50450 Kuala Lumpur

Tel +60 3 2181 6341 / 6342

Fax +60 3 2181 6335

Email sbnkl@sbnbiz.com

TERENGGANU OFFICE

K431 Taman Kemaman
24000 Chukai Kemaman, Terengganu

Tel +60 9 859 7600

Fax +60 9 859 7701

Email sbnkmm@sbnbiz.com

SARAWAK OFFICE

Lot 1167, Blok 10 KBLD, Lutong Baru Shophouse,
PO Box 1075, 98008 Miri, Sarawak

Tel +60 85 651 600

Fax +60 85 655 604

Email sbnmiri@sbnbiz.com

SABAH OFFICE

Lot F-4-28, 4th Floor, Block F, Tanjung Aru Plaza,
88100 Kota Kinabalu, Sabah, Malaysia.

Tel +60 88 211 509

Fax +60 88 211 509

Email ian@sbnbiz.com

DIMET[®]

Cathodic Protection Products & Services

Pile-Gard[®]

Splashzone Wrapping System

FSI

Flange Insulation Kits
and Monolithic Joints

M★RAK[®]

Cable Support Systems

MASTERCOTE[®]

Fluorocarbon Coated Bolts & Nuts

Bolting Solutions

Sales and Rental of Hydraulic
Bolting Equipments & Tools

MCM
MC MILLER Co.

Cathodic Protection
Monitoring Equipment